



DSP7

PILOT OPERATED DISTRIBUTOR SOLENOID OR HYDRAULIC (DSC7) CONTROLLED

SUBPLATE MOUNTING
ISO 4401-07 (CETOP 07)

p max 350 bar
Q max 300 l/min

MOUNTING INTERFACE

ISO 4401-07-07-0-05
(CETOP 4.2-4-07-350)

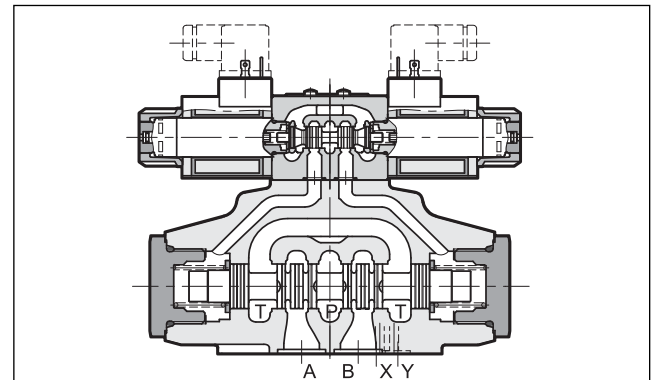
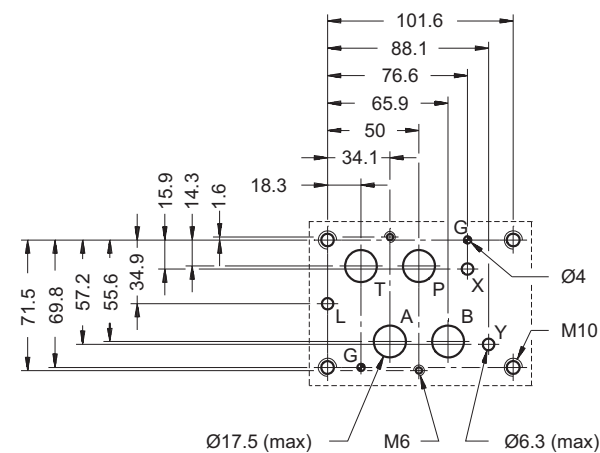

- The DSP7 piloted valve is made up of a 4-way hydro-piloted distributor with mounting surface according to ISO 4401-07 (CETOP 07) (CETOP RP121H) standards, operated by an ISO 4401-03 (CETOP 03) solenoid directional valve.
- It is available with different spool types (see par. 2), with some options for the opening control.
- It is available with both the solenoid and the hydraulic control from the X and Y ways
- A version for high pressures (H) is available.

PERFORMANCES (obtained with mineral oil of viscosity of 36 cSt at 50°C)

		DSP7	DSP7H
Maximum operating pressure	- ports P - A - B	350	420
	- port T (external drainage)	210	350
	- port T (internal drainage)	140	140
		bar	
Maximum flow rate from port P to A - B - T	l/min	300	
Ambient temperature range	°C	-20 / +50	
Fluid temperature range	°C	-20 / +80	
Fluid viscosity range	cSt	10 ÷ 400	
Fluid contamination degree	according to ISO 4406:1999 class 20/18/15		
Recommended viscosity	cSt	25	
Mass:	DSP7-S, RK	8,6	
	DSP7-T*, SA*, SB*	8,0	
	DSC7	6,6	
	kg		

1 - IDENTIFICATION CODE FOR SOLENOID DISTRIBUTOR DSP7

D	S	P	7	-	/	20	-	/	/	K1	/	
----------	----------	----------	----------	----------	----------	-----------	----------	----------	----------	-----------	----------	--

Directional valve, Solenoid controlled, Pilot operated

Size: _____
ISO 4401-07 (CETOP 07)

Option: (omit for standard version) _____
H = high pressure version
pmax = 420 bar
not available with S4, SA4, SB4 spools.

Spool type (see paragraph 2) _____
S* **TA**
SA* **TB**
SB* **RK**

Series: (the overall and mounting dimensions remain unchanged from 20 to 29) _____

Seals: _____
N = NBR seals for mineral oil (**standard**)
V = FPM seals for special fluids

Piloting (see paragraph 9): _____
I = internal (not available for spools S2 - S4 - S7 - S8 - TA02
TB02 -RK02 - S*2 - S*4. If internal pilot is required, choose pilot type C)
C = internal piloting with backpressure valve
Z = internal piloting with 30 bar fixes adjustment pressure reducing valve
(see paragraph 8)
E = external

Drainage (see paragraph 9): _____
I = Internal
E = External

Controls: _____
C = Main spool stroke control (see paragraph 13.1)
D = Main spool switching speed control (see paragraph 13.2)
P08 = Subplate placed under solenoid valve with restrictor of Ø0.8 on port P
(see paragraph 13.3)
S2 = Distributor delivered with pilot solenoid valve in configuration S2
(see paragraph 13.4)

Manual override:
omit for override integrated in the tube (**standard**)
CM = manual override, boot protected (see paragraph 14)

Coil electrical connection:
plug for connector type DIN 43650 (**standard**)

DC power supply
D12 = 12 V
D24 = 24 V
D48 = 48 V
D110 = 110 V
D220 = 220 V
D00 = valve without coils (see **NOTE**)

AC power supply
A24 = 24 V - 50 Hz
A48 = 48 V - 50 Hz
A110 = 110 V - 50 Hz / 120 V - 60 Hz
A230 = 230 V - 50 Hz / 240 V - 60 Hz
A00 = valve without coils (see **NOTE**)
F110 = 110 V - 60 Hz
F220 = 220 V - 60 Hz

NOTE: The locking rings of the coils and the relevant O-Rings are supplied together with valves

2 - SPOOL TYPE

NOTE: Symbols refers to the **DSP7** solenoid valve.

For the **DSC7** hydraulic control version, please verify the connection scheme at paragraph 3.

Type S*:
2 solenoids - 3 positions
with spring centering

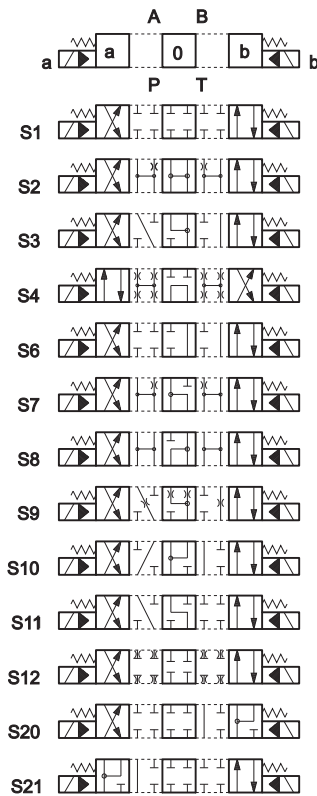

Type SA*:
1 solenoid side A
2 positions (central + external)
with spring centering

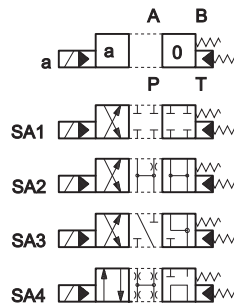

Type SB*:
1 solenoid side B
2 positions (central + external)
with spring centering

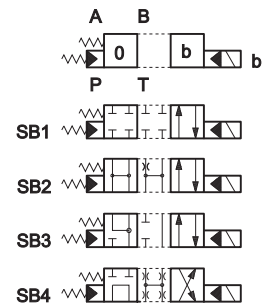

Type TA:
1 solenoid side A
2 external positions
with return spring

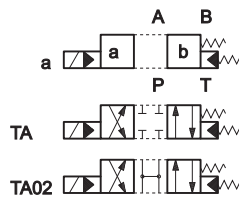

Type TB:
1 solenoid side B
2 external positions
with return spring

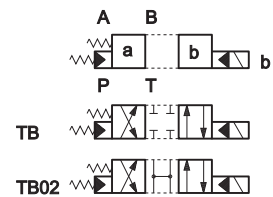

Type RK:
2 solenoids - 2 positions
with mechanical retention

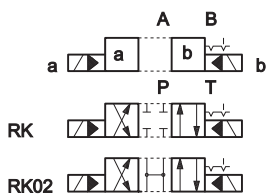

Type TA23 / TB23

three-way valve - 1 solenoid - 2 external positions, return spring

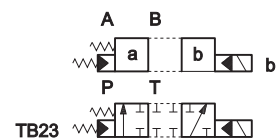
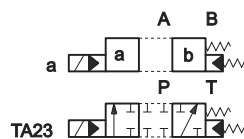

Besides the diagrams shown, which are the most frequently used, other special versions are available: consult our technical department for their identification, feasibility and operating limits.

3 - IDENTIFICATION CODE FOR HYDRAULIC DISTRIBUTOR DSC7

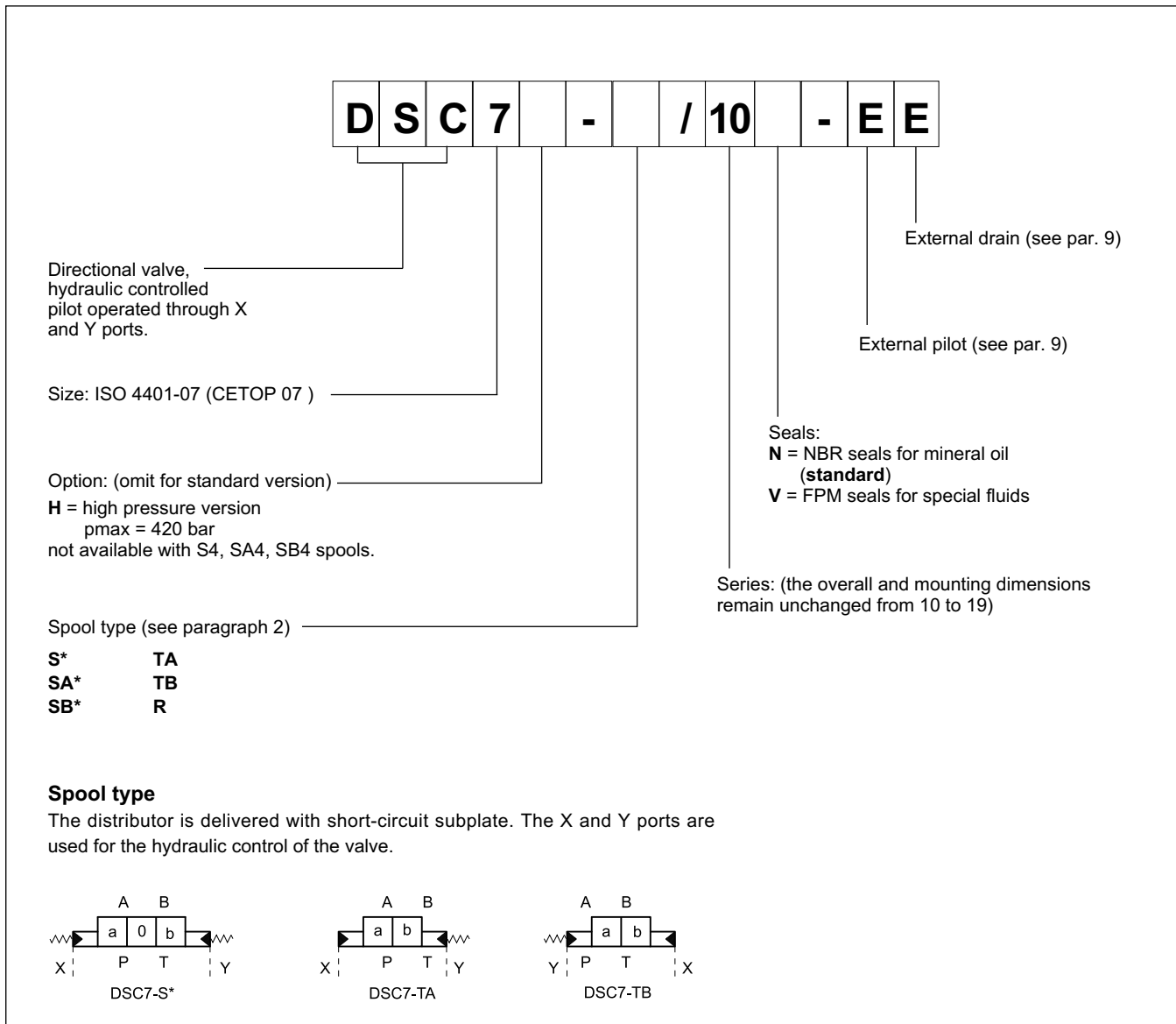

4 - HYDRAULIC FLUIDS

Use mineral oil-based hydraulic fluids HL or HM type, according to ISO 6743-4. For these fluids, use NBR seals (code N). For fluids HFDR type (phosphate esters) use FPM seals (code V).

For the use of other kinds of fluid such as HFA, HFB, HFC, please consult our technical department. Using fluids at temperatures higher than 80 °C causes a faster degradation of the fluid and of the seals characteristics.

The fluid must be preserved in its physical and chemical characteristics.

5 - PRESSURE DROPS Δp -Q (values obtained with viscosity 36 cSt at 50 °C)

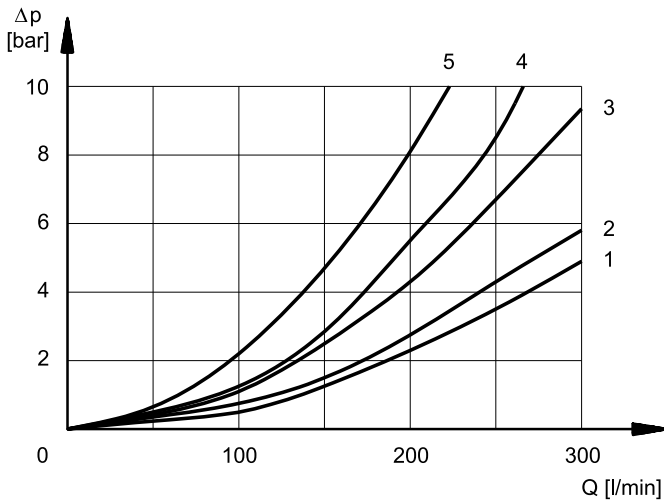

PRESSURE DROPS WITH VALVE ENERGIZED

SPOOL TYPE	FLOW DIRECTION			
	P-A	P-B	A-T	B-T
	CURVES ON GRAPH			
S1, SA1, SB1	1	1	3	4
S2, SA2, SB2	1	1	4	4
S3, SA3, SB3	1	1	4	4
S4, SA4, SB4	2	2	4	5
S6	1	1	3	4
S7	1	1	4	4
S8	1	1	3	4
S9	1	1	3	4
S10	1	1	3	4
S11	1	1	3	4
S12	1	1	3	4
S20	1	1	3	4
S21	1	1	4	4
TA, TB	1	1	3	4
TA02, TB 02	1	1	4	4
RK	1	1	3	4

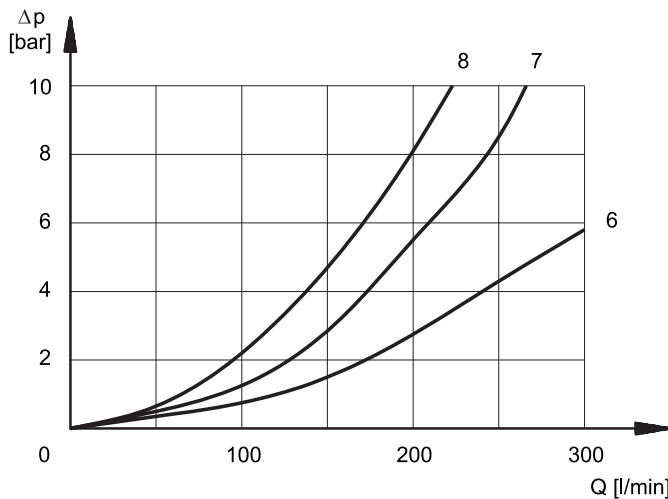

PRESSURE DROPS WITH VALVE IN DE-ENERGIZED POSITION

SPOOL TYPE	FLOW DIRECTION				
	P-A	P-B	A-T	B-T	P-T
	CURVES ON GRAPH				
S2, SA2, SB2					6
S3, SA3, SB3			7	7	
S4, SA4, SB4					7
S6				7	
S7					8
S8					8
S10			7	7	
S11			7		

6 - SWITCHING TIMES

The values indicated refer to a solenoid valve working with piloting pressure of 100 bar, with mineral oil at a temperature of 50°C, at viscosity of 36 cSt and with PA and BT connections. The energizing and de-energizing times are obtained at the pressure variation which occurs on the lines.

TIMES ($\pm 10\%$) [ms]	ENERGIZED		DE-ENERGIZED	
	2 Pos.	3 Pos.	2 Pos.	3 Pos.
	AC solenoid	45	30	45
DC solenoid	75	60	60	45

7 - OPERATING LIMITS

The curves define the flow rate operating fields according to the valve pressure for the different spool types.

The values have been obtained according to ISO 6403 norm with solenoids at rated temperature and supplied with voltage equal to 90% of the nominal voltage.

The values have been obtained with mineral oil, viscosity 36 cSt at 50 °C, and filtration ISO 4406:1999 class 18/16/13.

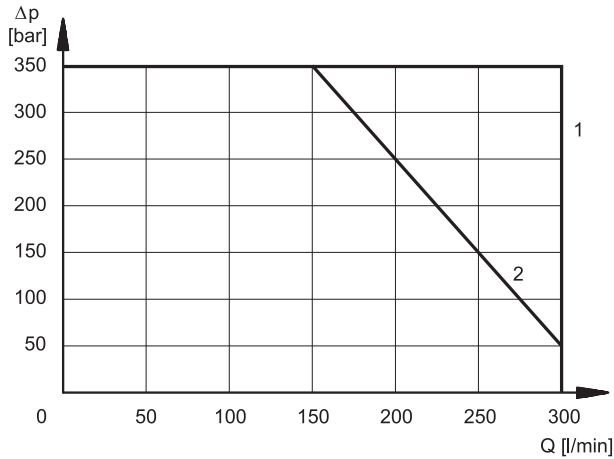

SPOOL TYPE	CURVE	
	P-A	P-B
S1,SA1,SB1	1	1
S2, SA2, SB2	1	1
S3, SA3, SB3	1	1
S4, SA4, SB4	2	2
S6	1	1
S7	2	2
S8	2	2

SPOOL TYPE	CURVE	
	P-A	P-B
S9	1	1
S10	1	1
S11	1	1
S12	1	1
S20	1	1
S21	1	1
TA, TB	1	1
TA02, TB02	1	1
TA23, TB23	1	1
RK	1	1

8 - PERFORMANCE CHARACTERISTICS

PRESSURES [bar]		DSP7	DSP7H	DSC7	DSC7H
	MIN	MAX			
Pressure in P, A, B ports		350	420	350	420
Piloting pressure (X port and / or Y port)	12 (a)	210 (b)	350	210	350
Pressure in T line with internal drainage	-	140	140	-	-
Pressure in T line with external drainage	-	210	350	210	350

NOTES:

a) The minimum piloting pressure can be of 6 bar at low flows rates, but with higher flow rates a pressure of 12 bar is needed.

b) If the valve operates with higher pressures it is necessary to use the version with external pilot and reduced pressure. Otherwise, the valve with internal pilot and pressure reducing valve with 30 bar fixed adjustment can be ordered.

9 - PILOTING AND DRAINAGE

The DSP7 valves are available with piloting and drainage, both internal and external. The version with external drainage allows for a higher back pressure on the outlet.

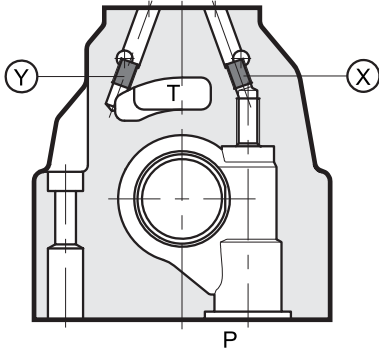

X: plug M6x8 for external pilot
Y: plug M6x8 for external drain

TYPE OF VALVE	Plug assembly	
	X	Y
IE INTERNAL PILOT AND EXTERNAL DRAIN	NO	YES
II INTERNAL PILOT AND INTERNAL DRAIN	NO	NO
EE EXTERNAL PILOT AND EXTERNAL DRAIN	YES	YES
EI EXTERNAL PILOT AND INTERNAL DRAIN	YES	NO

9.1 - Backpressure valve incorporated on line P

Valves DSP7 are available upon request with backpressure valve incorporated on line P. This is necessary to obtain the piloting pressure when the control valve, in rest position, has the line P connected to the T port (spools S2, S4, S7, S8, S*2, S*4, TA02, TB02, RK02). The cracking pressure is of 5 bar with a minimum flow rate of 15 l/min.

Add **C** to the identification code for this request (see paragraph 1).

In the C version the piloting is always internal.

The backpressure valve can be also delivered separately and it can be easily mounted on line P of the main control valve. Specify the code **0266577** to order the backpressure valve separately.

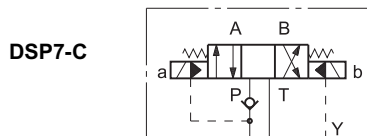

DSP7-C

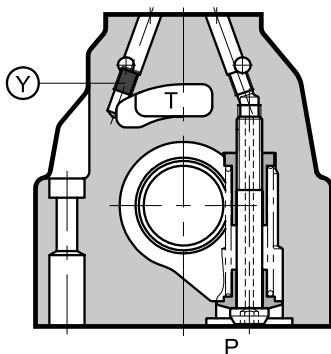

pilot always internal
Y: plug M6x8 for external drain

NOTE: the backpressure valve can't be used as check valve because it doesn't assure the seal.

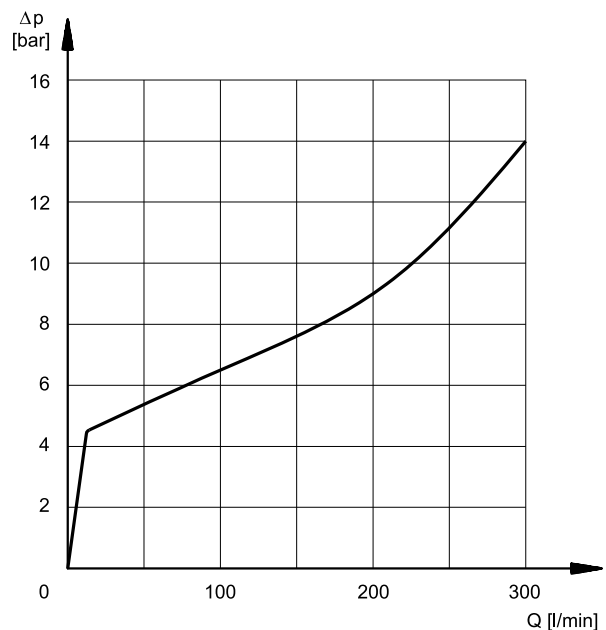

The curve refers to the pressure drop (body part only) with backpressure valve energized to which the pressure drop of the reference spool must be added. (see paragraph 5)

10 - ELECTRICAL FEATURES

10.1 Solenoids

These are essentially made up of two parts: tube and coil. The tube is threaded into the valve body and includes the armature that moves immersed in oil, without wear. The inner part, in contact with the oil in the return line, ensures heat dissipation.

The coil is fastened to the tube by a threaded ring, and can be rotated 360°, to suit the available space.

NOTE 1: In order to further reduce the emissions, use of type H connectors is recommended. These prevent voltage peaks on opening of the coil supply electrical circuit (see CAT. 49 000).

NOTE 2: The IP65 protection degree is guaranteed only with the connector correctly connected and installed.

VOLTAGE SUPPLY FLUCTUATION	± 10% Vnom
MAX SWITCH ON FREQUENCY	10.000 ins/hr
DUTY CYCLE	100%
ELECTROMAGNETIC COMPATIBILITY (EMC) (NOTE 1)	In compliance with 2004/108/CE
LOW VOLTAGE	In compliance with 2006/95/CE
CLASS OF PROTECTION: Atmospheric agents (CEI EN 60529) Coil insulation (VDE 0580) Impregnation: CC valve CA valve	IP 65 (NOTE 2) class H class F class H

10.2 Current and absorbed power for DC solenoid valve

The table shows current and power consumption values relevant to the different coil types for DC.

The rectified current supply takes place by fitting the valve (with the exception of D12 coil) with an alternating current source (50 or 60 Hz), rectified by means of a bridge built-in to the "D" type connectors (see cat. 49 000), by considering a reduction of the operating limits by 5 ÷ 10% approx.

Coils for direct current (values ± 5%)

Suffix	Nominal voltage [V]	Resistance at 20°C [ohm]	Current consumpt. [A]	Power consumpt. [W]	Coil code
D12	12	4,4	2,72	32,7	1903080
D24	24	18,6	1,29	31	1903081
D48	48	78,6	0,61	29,5	1903083
D110	110	423	0,26	28,2	1903084
D220	220	1692	0,13	28,2	1903085

10.3 Current and absorbed power for AC solenoid valve

The table shows current and power consumption values at inrush and at holding, relevant to the different coil types for AC current.

Coils for alternating current (values ± 5%)

Suffix	Nominal voltage [V]	Frequency [Hz]	Resistance at 20°C [ohm]	Current consumption at inrush [A]	Current consumption at holding [A]	Power consumption at inrush [VA]	Power consumption at holding [VA]	Coil code
A24	24	50	1,46	8	2	192	48	1902830
A48	48	50	5,84	4,4	1,1	204	51	1902831
A110	110V-50Hz	50/60	32	1,84	0,46	192	48	1902832
	120V-60Hz			1,56	0,39	188	47	
A230	230V-50Hz		140	0,76	0,19	176	44	1902833
	240V-60Hz			0,6	0,15	144	36	
F110	110	60	26	1,6	0,4	176	44	1902834
F220	220		106	0,8	0,2	180	45	1902835

11 - OVERALL AND MOUNTING DIMENSIONS FOR SOLENOID DISTRIBUTOR DSP7

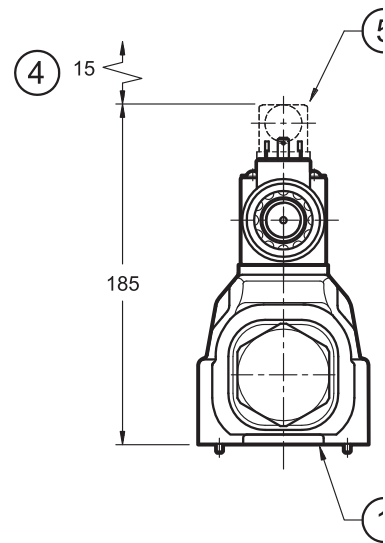
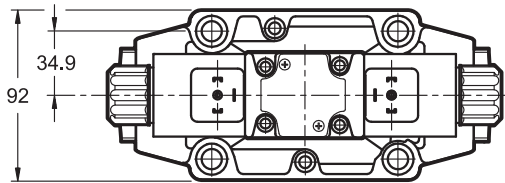
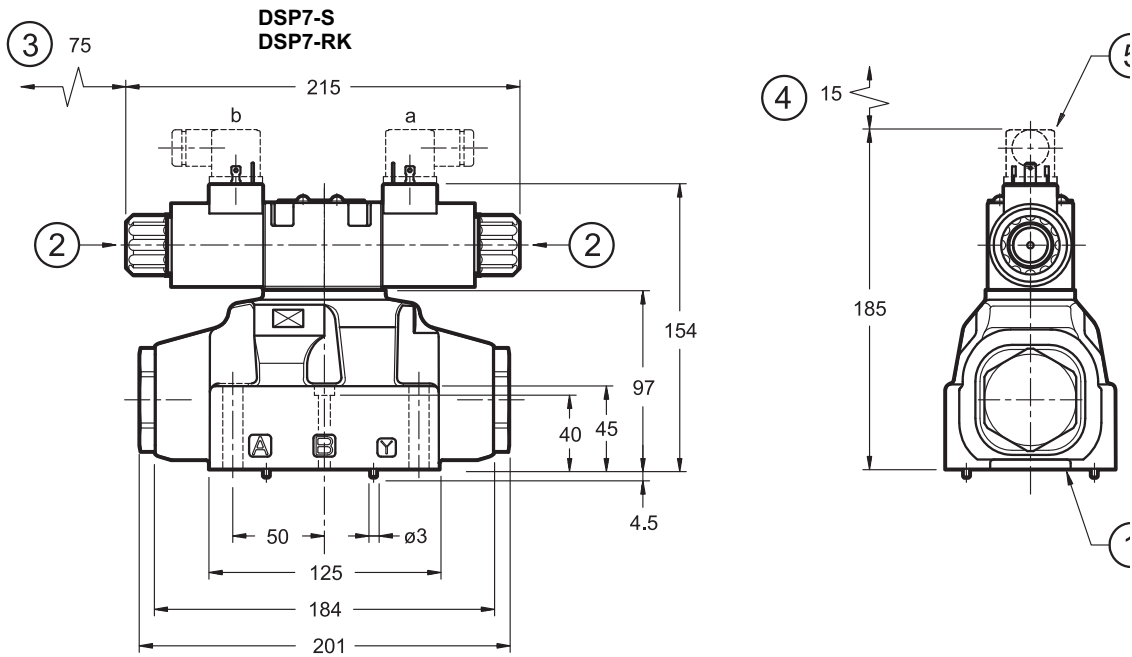

DSP7-TA
DSP7-SA*

solenoid position
configuration TB/SB*

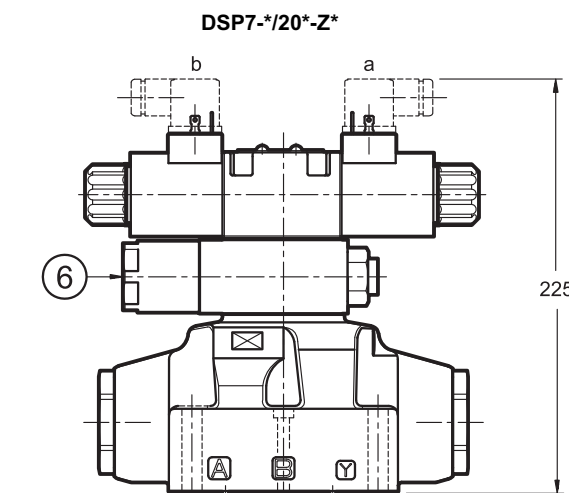
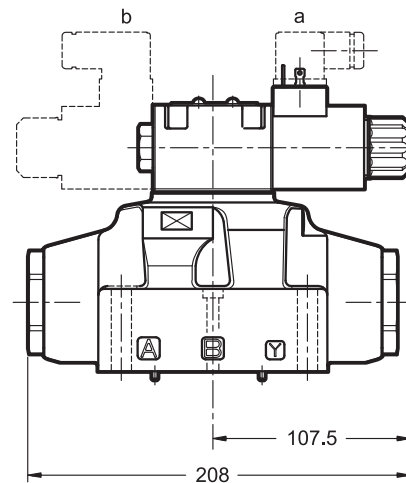

dimensions in mm

Fastening of single valve: 4 SHC screws ISO 4763 M10x60 (see par. 16) 2 SHC screws ISO 4763 M6x50
Tightening M10x60: 40 Nm (A 8.8 screws) - 67 Nm (A 12.9 screws) torque: M6x50: 8 Nm (A 8.8 screws) - 14 Nm (A 12.9 screws)
Threads of mounting holes: M6x12; M10x18
Sealing rings: 4 OR type 130 (22.22x2.62) - 90 Shore 2 OR type 2043 (10.82x1.78) - 90 Shore

1	Mounting surface with sealing rings
2	Manual override
3	Coil removal space
4	Connector removal space
5	Electric connector to be ordered separately (see cat. 49 000)
6	Reducing valve with fixed adjustment 30 bar

NOTE: Use of class 12.9 fastening screws is recommended for valves in version H (high pressure).

12 - OVERALL AND MOUNTING DIMENSIONS FOR HYDRAULIC DISTRIBUTOR DSC7

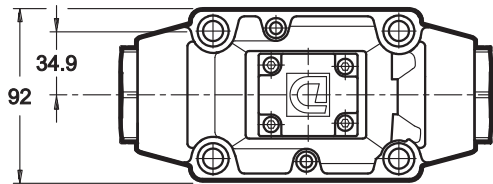
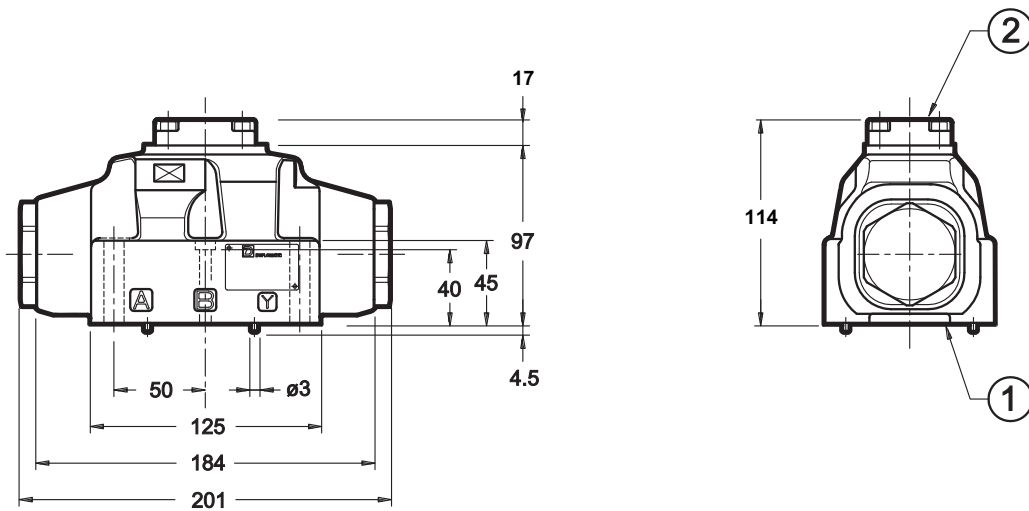

Fastening of single valve: 4 SHC screws ISO 4763 M10x60 (see par. 16)	2 SHC screws ISO 4763 M6x50
Tightening torque: M10x60: 40 Nm (A 8.8 screws) - 67 Nm (A 12.9 screws)	M6x50: 8 Nm (A 8.8 screws) - 14 Nm (A 12.9 screws)
Threads of mounting holes: M6x12; M10x18	
Sealing rings: 4 OR type 130 (22.22X2.62) - 90 Shore	
2 OR type 2043 (10.82x1.78) - 90 Shore	

dimensions in mm

1	Mounting surface with sealing rings
2	Short-circuit subplate

NOTE: Use of class 12.9 fastening screws is recommended for valves in version H (high pressure).

13 - OPTIONS

13.1 Control of the main spool stroke: C

With the help of special side plugs, it is possible to introduce stroke controls in the heads of the piloted valve so as to vary the maximum spool clearance opening.

This solution allows control of the flow rate from the pump to the actuator and from the actuator to the outlet, obtaining a double adjustable control on the actuator.

Add the letter **C** to the identification code to request this device (see paragraph 1).

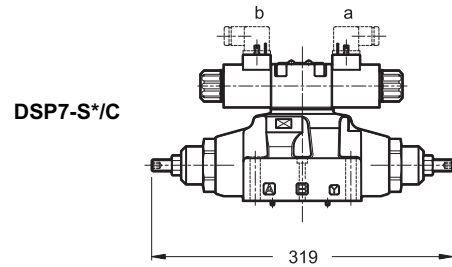

13.2 Control of the main spool shifting speed: D

By placing a MERS type double flow control valve between the pilot solenoid valve and the main distributor, the piloted flow rate can be controlled and therefore the changeover smoothness can be varied.

Add the letter **D** to the identification code to request this device (see paragraph 1).

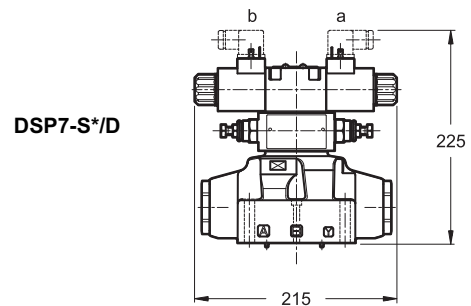

13.3 Subplate with throttle on line P

It is possible to introduce a subplate with a restrictor of $\varnothing 0,8$ on line P between the pilot solenoid valve and the main distributor.

Add **P08** to the identification code to request this option (see paragraph 1).

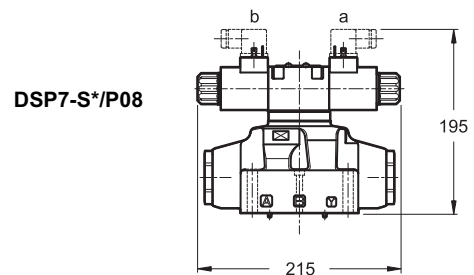

13.4 Solenoid operated distributor with pilot valve in configuration S2

It is possible to deliver the solenoid operated distributor with pilot valve in configuration S2 (all the ports at outlet). With this option the piloting is necessarily external.

Add **S2** to the identification code to request this option (see paragraph 1).

This configuration is used with external piloting in order to allow the unloading of the piloting line when the solenoid operated valve is in rest position.

14 - MANUAL OVERRIDE, BOOT PROTECTED: CM

Whenever the solenoid valve installation may involve exposure to atmospheric agents or use in tropical climates, the manual override, boot protection is recommended.

Add the suffix **CM** to request this device (see paragraph 1).

For overall dimensions see cat. 41 150.

15 - ELECTRIC CONNECTORS

The solenoid operated valves are delivered without the connectors. They must be ordered separately.

For the identification of the connector type to be ordered, please see catalogue 49 000.

16 - INSTALLATION

Configurations with centering and recall springs can be mounted in any position; type RK valves - without springs and with mechanical detent - must be mounted with the longitudinal axis horizontal.

Valve fastening takes place by means of screws or tie rods, laying the valve on a lapped surface, with values of planarity and smoothness that are equal to or better than those indicated in the drawing. If the minimum values of planarity or smoothness are not met, fluid leakages between valve and mounting surface can easily occur.

NOTE: Use of class 12.9 fastening screws is recommended for valves in version **H** (high pressure).

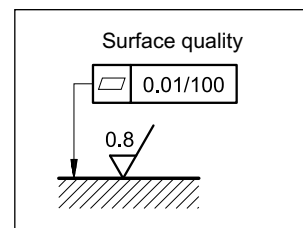

17 - SUBPLATES (see catalogue 51 000)

These plates are for the standard valves only. They are not suitable for high pressure (H) versions .

Type with rear ports	PME07-AI6G
Type with side ports	PME07-AL6G
P, T, A, B, port dimensions	1" BSP
X, Y; L port dimensions	1/4" BSP