



**LTR Series**  
**Light Duty Hydraulic**  
**Rack & Pinion Rotary Actuators**

Market Segments and Applications	A28
Features	A29
Ordering Information	A30-A31
Specifications	A32
Engineering Data	A33-A35
Dimensional Data	A36
Options	
Three-Position Actuator	A37
Antibacklash Actuator	A38
Port Threads, Port Location	A39
Cushions	A40
Stroke Adjusters	A41
Port Flow Controls	A41
Mounting	A42
Shaft	A43
Magnetic Piston	A44
Shaft Seal Cover	A44
Seals, Feedback	A45
Proximity Sensors	A46

**A**

**Rack & Pinion  
 Actuators**

**HUB  
 Series**

**LTR  
 Series**

**HTR  
 Series**

**M  
 Series**

			Product Series					
			HUB	LTR	HTR	M	Tork-Mor	
			Market/Segment	Typical Application(s)				
<b>Market Segments/Applications</b>	<b>A</b> Rack & Pinion Actuators	Aerospace	Water bomb, tank door actuation			●		
		Aggregate	Granite block rollover				●	
		Aluminum	Automation				●	
		Automation	Mounting, Processing, Flood gate actuation, End of arm tooling		●	●	●	●
		Automotive	Automation, Clamping, Tube bending				●	●
		Conveyor	Swing & rotate			●	●	●
		Entertaining	Pool gate actuation, Robotic joint motion					●
	HUB Series	Fluid Management & Flow Control	Power plants				●	●
		Industrial	Automation, Clamping					●
	LTR Series	Machine Builders	End of arm tooling				●	
		Marine/Offshore	Boomslewer, Submersible				●	●
	HTR Series	Mining	Mobile longhole drilling, Tunnel boring		●		●	●
		Mobile	Fire truck ladder rotation, Aerial lift basket, X-ray boom rotation, Forklift handling & storage, Refuse tippers		●	●	●	●
	M Series	Nuclear	Door actuation				●	
		Oil & Gas	Process valve actuation		●		●	
		Oil Industry Machinery	Clamping, Lockout		●			●
		Paper & Pulp	Walking beam				●	
		Plastics	Blow molding, Injection molding				●	●
		Rubber	Mixing				●	●
		Solar	Panel rotation				●	
		Space	Rocket launch tower				●	
	Steel & Casting	Ladle Tilt, Coil Box, Steel Booming, Pipe fabrication				●	●	
	Testing Equipment	Flight Simulators, Cycle loading, Tensile test Machines				●	●	
	Transportation	Bus wheelchair ramp			●			
	Water Management			●		●		
	Welding	Weld gun indexing, Clamping					●	

**LTR Series**

**RACK & PINION** made from through hardened, high strength alloy steels for long and durable service life in most applications.

**HOUSING** High strength housing serves as a firm base to drive large torque requirements.

**OPTIONAL CUSHIONS**

If properly adjusted, cushions can serve as a braking device for most industrial applications. The proven Parker "floating cushion bushing" serves as a high performance check valve for "quick get away" and the needle valve can be adjusted to regulate the exhaust flow from the piston. Our design uses no springs or check valve seats that can break under normal usage.

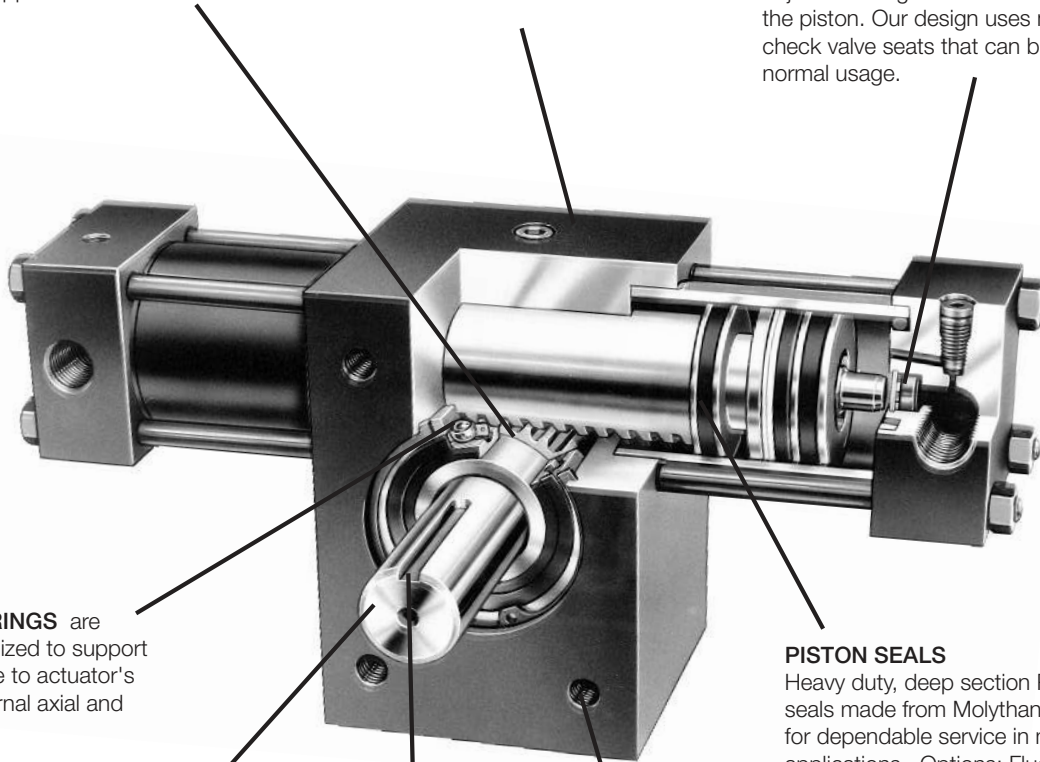

**BALL BEARINGS** are generously sized to support large (relative to actuator's weight) external axial and radial loads.

**STANDARD MALE KEYED SHAFT** is made integral with the pinion gear and is suitable for most applications. Options: double male key, hollow bore keyed and splined shafts are available.

**KEYWAY** mid stroke at 12:00 position is standard.

**PISTON SEALS**

Heavy duty, deep section Polypak seals made from Molythane for dependable service in most applications. Options: Fluorocarbon seals for certain synthetic fluids; and carboxylated nitrile seals for water based fluids. Piston seals can be inspected and replaced without disconnecting the load from the shaft. (Employ proper safety practices to prevent damage to people or equipment.)

**THREADED MOUNTING HOLES**

Our standard mounting has four bolt holes drilled and tapped on the front and back of the housing. Options: pilot ring or base mount.

**A**

**Rack & Pinion Actuators**

**HUB Series**

**LTR Series**

**HTR Series**

**M Series**

**Ordering information – Inch**

**A**  
 Rack & Pinion  
 Actuators

HUB  
 Series

LTR  
 Series

HTR  
 Series

M  
 Series

**LTR 25 1 - 090 3 F P - A B 2 1 M V - C**

Model	
10	1" bore
15	1-1/2" bore
20	2" bore
25	2-1/2" bore
32	3-1/4" bore

Rotation <sup>1</sup>	
090	90°
180	180°
270	270°
360	360°

Or specify any other rotation.

Configuration	
1	Single rack
2	Double rack
3	Three position actuator
7	Antibacklash

Cushions	
Omit	None
1	Cushioned CW rotation *
2	Cushioned CCW rotation *
3	Cushioned both rotations
4	Four cushions **
8	High performance cushion **
9	Special

Stroke adjusters	
Omit	None
D	0-30° CW rotation *^
E	0-30° CCW rotation *^
F	0-30° both rotations *^
X	Special

Mounting	
A	Face/base (standard)
F	Front flange
G	Foot flange
P	Pilot ring
R	Rear flange
X	Special

Port flow controls	
Omit	None
P	Flow control both rotations
R	Flow control CW rotation *
S	Flow control CCW rotation *

Shaft	
A	Female keyed
B	Single male keyed (standard)
C	Double male keyed
R	Preload keyway
X	Special

Port location	
1	Position 1 (standard)
2	Position 2
3	Position 3
4	Position 4
9	Special

Port threads	
1	SAE straight thread (standard)
2	NPTF
9	Special

Design series	
C	Current

Special Options	
Omit	Standard
Two or three-digit code assigned by factory and applies when any "X" or "9" appears in the model number or when special options or features are required.	

Seals	
Omit	Nitrile (standard)
V	Fluorocarbon
W	Carboxylated nitrile
X	Special

Standard options	
Omit	None
H	Resolver feedback
J	Potentiometer
M	Magnetic piston ring
S	Shaft seal cover <sup>Δ</sup>

**Notes:**

<sup>1</sup> For 3-position units, specify middle and total rotation separated by a "/", ie 045/180.

\* Viewed from shaft end

\*\* Double rack models only

^ Reduces to 10° with cushions

Δ For use with standard male shafts only

Other options	
Detail in clear text: Proximity switches – Specify high or low range, rotation direction.	

**Ordering information – Metric**

**LTR 25 1 - 090 3 F P - B D 4 1 M V - C**

Model	
10	1" (25.4mm) bore
15	1-1/2" (38.1mm) bore
20	2" (50.8mm) bore
25	2-1/2" (63.5mm) bore
32	3-1/4" (82.6mm) bore

Rotation <sup>1</sup>	
090	90°
180	180°
270	270°
360	360°
Or specify any other rotation.	

Configuration	
1	Single rack
2	Double rack
3	Three position actuator
7	Antibacklash

Cushions	
Omit	None
1	Cushioned CW rotation *
2	Cushioned CCW rotation *
3	Cushioned both rotations
4	Four cushions **
8	High performance cushion **
9	Special

Stroke adjusters	
Omit	None
D	0-30° CW rotation *^
E	0-30° CCW rotation *^
F	0-30° both rotations *^
X	Special

Mounting	
B	Face/base (standard)
H	Front flange
K	Foot flange ◊
S	Pilot ring
T	Rear flange
X	Special

Port flow controls	
Omit	None
P	Flow control both rotations
R	Flow control CW rotation *
S	Flow control CCW rotation *

Shaft	
D	Single male keyed (standard)
E	Female keyed
F	Double male keyed
X	Special

Design series	
C	Current

Special Options	
Omit	Standard
Two or three-digit code assigned by factory and applies when any "X" or "g" appears in the model number or when special options or features are required.	

Seals	
Omit	Nitrile (standard)
V	Fluorocarbon
W	Carboxylated nitrile
X	Special

Standard options	
Omit	None
H	Resolver feedback
J	Potentiometer
M	Magnetic piston ring
S	Shaft seal cover <sup>Δ</sup>

Port location	
1	Position 1 (standard)
2	Position 2
3	Position 3
4	Position 4
9	Special

Port threads	
4	BSPP (standard)
5	DIN 3852/1
6	ISO 6149/1
1	SAE straight thread
2	NPTF
9	Special

Other options	
Detail in clear text: Proximity switches – Specify high or low range, rotation direction.	

**Notes:**

<sup>1</sup> For 3-position units, specify middle and total rotation separated by a "/", ie 045/180.

\* Viewed from shaft end

\*\* Double rack models only

◊ Not available on Size 32

^ Reduces to 10° with cushions

Δ For use with male shafts only

**A**

Rack & Pinion Actuators

HUB Series

LTR Series

HTR Series

M Series

The LTR series rotary actuator is ideal for low pressure hydraulic applications. The LTR Series actuator combines an alloy steel gear set with a high strength aluminum housing and Parker 3L or 2A Series cylinder components into an actuator suitable for years of trouble free service. The actuator maximizes volumetric efficiency by using self-energizing PolyPak seals. Mechanical efficiency is maximized by using antifriction bearings and Wear-pak® piston technology.



- Hydraulic cushions to minimize noise, vibration shock and assist deceleration control
- Reed, Hall Effect or proximity switches for position sensing
- End-of-rotation stroke adjusters for load position control and accurate rotation adjustment
- Built-in meter outflow control valves with reverse flow check valves provide a neat package
- Three position option can be used with many special machine and material handling applications

**Operating information**

Output Torques	1000 psi (69 bar): 395 in-lb to 22,813 in-lb
Nominal pressure:	1000 PSIG (69 bar) (3L cylinder pressure ratings apply)
Operating temperature range:	
Nitrile seals	-40°F to 180°F (-40°C to 82°C)
Flurocarbon seals	-20°F to 250°F (-29°C to 121°C)
Standard rotations:	90°, 180°, 270°, 360°, 450°
Rotational tolerance	-0°, +2°
Breakaway pressure:	30 PSIG (2 bar) maximum
Mounting orientation:	unrestricted
Standard timing:	Keyway in 12:00 position at midstroke
Recommended filtration:	ISO class 17/14 or better

**Specifications**

Single rack	Double rack <sup>2</sup>	Theoretical output torque <sup>1</sup> , in-lb versus input pressure, PSI (bar)						Gear train rating pitting life estimate 1 million cycles		Displacement per degree of rotation	Maximum angular backlash	Maximum rotational tolerance
		100 (7)	250 (17)	500 (34)	750 (52)	1000 (69)	1500 (103)	inch-lbf <sup>3</sup>	PSID <sup>4</sup>			
101		39	98	197	295	395	592	270	800	0.007	60	-0/+5
	102	79	197	395	592	-	-	580	800	0.014	60	-0/+5
151		118	294	590	885	1180	1770	665	650	0.021	45	-0/+4
	152	236	590	1180	1770	2360	3530	1400	650	0.042	45	-0/+4
201		282	705	1410	2115	2830	4240	1790	750	0.049	35	-0/+3
251		430	1074	2148	3222	4295	6443	2100	550	0.075	35	-0/+3
	202	565	1410	2820	4230	5650	8470	3790	750	0.099	35	-0/+3
	252	859	2148	4295	6442	8590	12885	4250	550	0.150	35	-0/+3
321		1141	2852	5703	8554	11407	-	3880	400	0.199	25	-0/+2
	322	2281	5703	11407	17110	22813	-	6160	300	0.398	25	-0/+2

1. As a precaution, consult factory whenever using the LTR with port flow controls, cushions, or stroke adjusters on double rack units. These options may require the units to be pressure derated.
2. Double rack actuators should specify type 4 or 8 cushions and four stroke adjusters and four flow controls (one per end cap) to balance the gear tooth forces on the pinion. Contact the factory for ordering code information. Type 1, 2, or 3 cushions, type A, B, or C stroke adjusters and type P, R, and S port flow controls may cause a destructive bending couple upon the pinion gear under some operating conditions.
3. Durability rated output torque.
4. Pressure differential between the inlet and outlet ports (non-shock).
5. Reduce LTR Series pressure rating by 50% when specifying a magnetic piston with aluminum cylinder tubes, option "M" except on LTR101 and 102 models, or when a unit has cushions.



**A**  
 Rack & Pinion Actuators  
 HUB Series  
 LTR Series  
 HTR Series  
 M Series

**Bearing Load Capacities & Gear Train Available**

Model	Bearing load capacities*				Distance		Available stopping work per endcap / cushion**			
	Radial		Thrust		between bearings		Strength criteria		Durability criteria	
	lb	kN	lb	kN	inch	mm	in-lb	Nm	in-lb	Nm
10	100	0.4	50	0.2	1.40	35	300	34	141	16
15	250	1.1	125	0.5	2.15	54	900	102	348	39
20	500	2.2	250	1.1	2.15	54	1500	169	936	106
25	750	3.3	375	1.6	2.50	63	2250	254	1098	124
32	1000	4.4	500	2.2	3.75	95	5000	565	2029	229

\* Bearing capacities only.

\*\* Check total stopping torque ratings to determine if actuator will stop load. Double rack actuators should use Type 4 or Type 8 cushion option for table data to remain correct.

**Cushion Deceleration Control**

The cushion causes the resisting torque that can be used to decelerate a rotational load. Please note the cushion has to provide enough resistance to control: drive torque caused by the hydraulic system pressure; plus the torque caused by gravity pulling on the rotational load; and the kinetic energy associated with the motion of the inertia load. Since the actuator's cushion has to be able to control the sum of all three torque factors, we suggest including cushion capacity as one of the actuator selection criteria.

It is strongly suggested that proportional valves be used instead of cushions to control (decelerate) high inertial loads. This provides the ability to reduce inlet pressure while generating deceleration pressure. It also allows for longer ramp times, thus increasing deceleration stroke.

**SUPPLEMENTAL INFORMATION  
 KINETIC ENERGY BASIC FORMULA**

$$KE = 1/2 J_m \omega^2$$

$$\omega = 0.0175 \times \frac{2\Theta_A + \Theta_C + 2\Theta_D}{\text{Rotation Time (sec.)}}$$

where:

KE = Kinetic Energy (in-lb)

J<sub>m</sub> = Rotational Mass Moment of Inertia (in-lb-sec<sup>2</sup>)

See Page 8 for formulas.

ω = Peak Velocity (rad/sec)

(Assuming trapezoidal velocity profile)

Θ<sub>A</sub> = Acceleration Angle (deg)

Θ<sub>C</sub> = Constant Velocity Angle (deg)

Θ<sub>D</sub> = Deceleration Angle (deg)

**A**

Rack & Pinion  
Actuators

HUB  
Series

LTR  
Series

HTR  
Series

M  
Series

### Kinetic Energy Capacity

The energy values below assume drive pressure is maintained through cushion stroke.

#### Single Rack Units with Single Set of Cushions (30°)

Model	Kinetic Energy Rating (in-lb) of Cushion at Specified Drive Pressure*											
	0 PSI		250 PSI		500 PSI		750 PSI		1000 PSI		1500 PSI	
	Max.	Durability	Max.	Durability	Max.	Durability	Max.	Durability	Max.	Durability	Max.	Durability
LTR101	310	141	258	141	207	141	155	141	103	103	0	0
LTR151	927	348	772	348	618	348	463	348	309	309	0	0
LTR201	2220	936	1850	936	1480	936	1110	936	740	740	0	0
LTR251	3373	1098	2811	1098	2248	1098	1686	1098	1124	1098	0	0
LTR321	11945	2029	8959	2029	5973	2029	2986	2029	0	0	na	na

#### Double Rack Units with Single Set of Cushions (30°)

Model	Kinetic Energy Rating (in-lb) of Cushion at Specified Drive Pressure*											
	0 PSI		250 PSI		500 PSI		750 PSI		1000 PSI		1500 PSI	
	Max.	Durability	Max.	Durability	Max.	Durability	Max.	Durability	Max.	Durability	Max.	Durability
LTR102	310	141	103	103	0	0	0	0	0	0	0	0
LTR152	924	348	616	348	308	308	0	0	0	0	0	0
LTR202	2217	936	1478	936	739	739	0	0	0	0	0	0
LTR252	3373	1098	2249	1098	1124	1098	0	0	0	0	0	0
LTR322	5971	2029	2986	2029	0	0	0	0	0	0	0	0

#### Double Rack Units with Double Set of Cushions (30°)\*\*

Model	Kinetic Energy Rating (in-lb) of Cushion at Specified Drive Pressure*											
	0 PSI		250 PSI		500 PSI		750 PSI		1000 PSI		1500 PSI	
	Max.	Durability	Max.	Durability	Max.	Durability	Max.	Durability	Max.	Durability	Max.	Durability
LTR102	310	303	206	206	103	103	0	0	0	0	0	0
LTR152	1848	732	1540	732	1232	732	924	732	616	616	0	0
LTR202	4434	1982	3695	1982	2956	1982	2217	1982	1478	1478	0	0
LTR252	6745	2223	5621	2223	4496	2223	3373	2223	2248	2223	0	0
LTR322	11943	3222	8957	3222	5971	3222	2986	2986	0	0	0	0

\* Must deduct work (energy) done to overcome potential energy effects of load.  $WPE = TPE \times \Theta$ , where  $\Theta$  is in radians.

\*\* Extreme care must be exercised so that both cushions are adjusted equally for each direction or dangerous pressure intensification and gear train stresses could result. (Suggest high performance cushion option.)

### Unit Weights

Model	Rotation 90°		180°		270°		360°	
	lb	kg	lb	kg	lb	kg	lb	kg
LTR101	2-1/4	1	2-1/2	1.1	2-3/4	1.2	3	1.3
LTR102	3-1/2	1.6	3-7/8	1.8	4-1/4	1.7	4-5/8	2.1
LTR151	8-7/8	4	9-5/8	4.3	10-3/8	4.7	11-1/8	5
LTR152	12-5/8	5.7	14-1/8	6.4	15-5/8	7.1	19-1/2	8.8
LTR201	14-5/8	6.6	16	7.2	17-3/8	7.9	18-7/8	8.6
LTR202	21-3/4	9.9	24-1/2	11.1	27-1/2	12.5	30-1/2	13.8
LTR251	22-5/8	10.3	24-3/4	11.2	27-1/4	12.4	29-3/8	13.3
LTR252	33-5/8	15.2	38-1/8	16.8	42-3/4	19.4	47-1/8	21.4
LTR321	46-5/8	21.1	50-1/8	22.7	53-1/2	24.3	56-7/8	25.8
LTR322	66-5/8	30.2	73-5/8	33.4	78-3/8	35.5	87-1/8	39.5



**Kinetic Energy Basic Formula**

$$KE = 1/2 J_m \omega^2$$

$$\omega = 0.0175 \times \frac{2\Theta_A + \Theta_C + 2\Theta_D}{\text{Rotation Time (Sec.)}}$$

where:

KE = Kinetic Energy (in-lb)

J<sub>m</sub> = Rotational mass moment of inertia (in-lb-sec<sup>2</sup>)  
 (Dependent on physical size of object and weight)

ω = Peak Velocity (rad/sec) (Assuming trapezoidal velocity profile)

Θ<sub>A</sub> = Acceleration Angle (deg)

Θ<sub>C</sub> = Constant Velocity Angle (deg)

Θ<sub>D</sub> = Deceleration Angle (deg)

W = Weight of load (lb)

g = Gravitational constant = 386.4 in/sec<sup>2</sup>

k = Radius of gyration (in)

**MASS MOMENTS OF INERTIA  
 MODELS & FORMULAS**

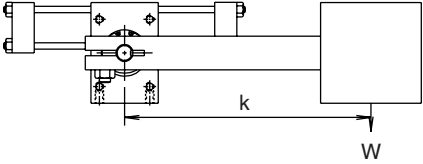
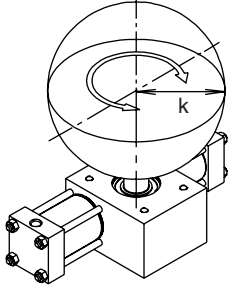
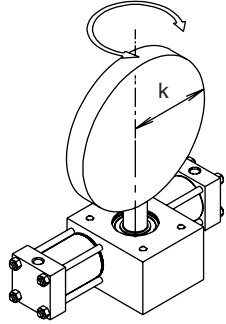
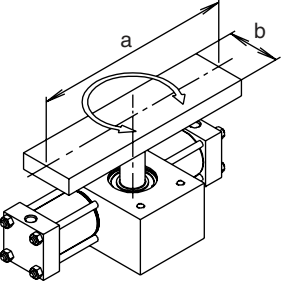
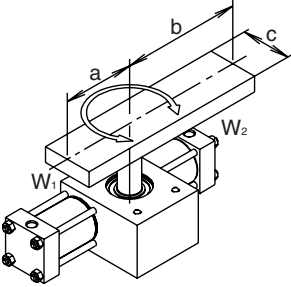
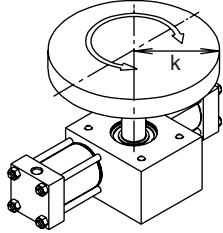
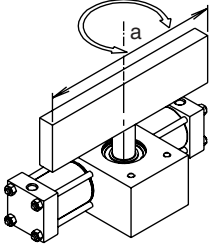
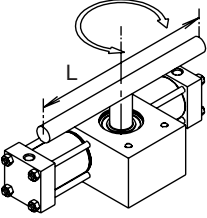
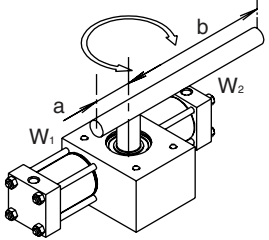
<p><b>POINT LOAD</b></p>  $J_m = \frac{W}{g} \times k^2$	<p><b>SOLID SPHERE -                      Mounted on center</b></p>  $J_m = \frac{2}{5} \times \frac{W}{g} \times k^2$	<p><b>THIN DISK-                      End mounted on center</b></p>  $J_m = \frac{W}{g} \times \frac{k^2}{4}$
<p><b>THIN RECTANGULAR PLATE                      Mounted on center</b></p>  $J_m = \frac{W}{g} \times \frac{a^2 + b^2}{12}$	<p><b>THIN RECTANGULAR PLATE                      Mounted off center</b></p>  $J_m = \frac{W_1}{g} \times \frac{4a^2 + c^2}{12} + \frac{W_2}{g} \times \frac{4b^2 + c^2}{12}$	<p><b>THIN DISK                      Mounted on center</b></p>  $J_m = \frac{W}{g} \times \frac{k^2}{2}$
<p><b>THIN RECTANGULAR PLATE                      End mounted on center</b></p>  $J_m = \frac{W}{g} \times \frac{a^2}{12}$	<p><b>SLENDER ROD                      Mounted on center</b></p>  $J_m = \frac{W}{g} \times \frac{L^2}{12}$	<p><b>SLENDER ROD                      Mounted off center</b></p>  $J_m = \frac{W_1}{g} \times \frac{a^2}{3} + \frac{W_2}{g} \times \frac{b^2}{3}$

**A**

Rack & Pinion  
 Actuators

HUB  
 Series

LTR  
 Series

HTR  
 Series

M  
 Series

**Standard Inch Unit with Face/Base Mount (A) and Male Keyed Shaft (B)**

**Standard Metric Unit with Face/Base Mount (B) and Male Keyed Shaft (D)**

Double Male Keyed Shaft (C, F) shown in phantom

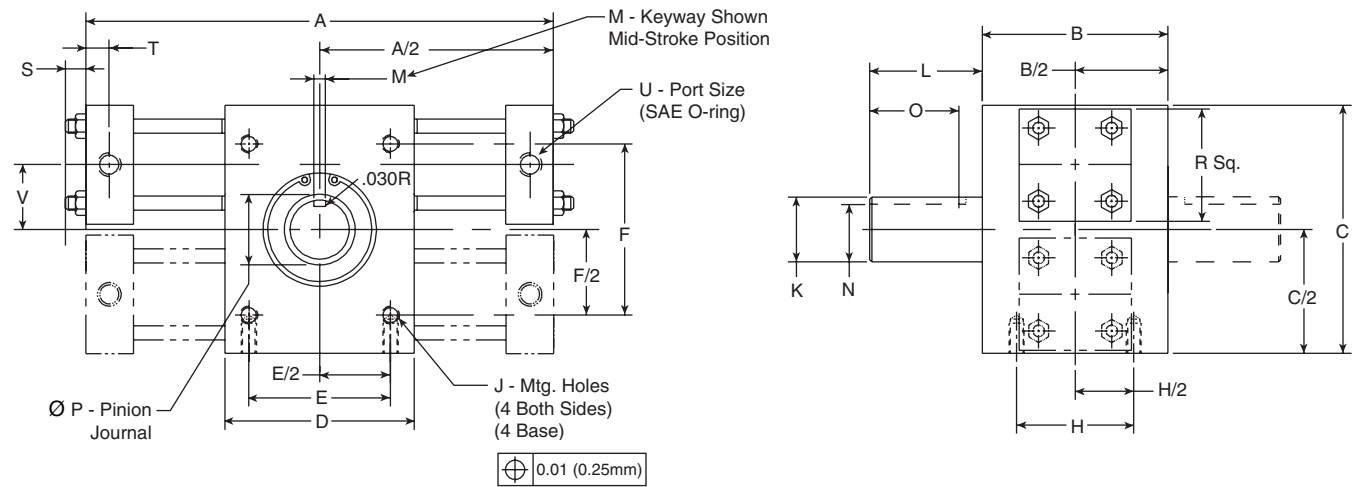

**Dimensions for inch units (inches)**

Model	Rotation	A	B	C	D	E	F	H	J	K	L	M	N	O	P	R	S	T	U	V
10	90°	6-11/16																		
	180°	8-1/4	2	3	2	1.50	2.00	1.50	1/4-20 x 3/8 DP	.500 .499	7/8	.125 .127	.430 .425	5/8	.59	1-1/2	.39	.31	7/16-20 SAE #4	3/4
	360°	1-17/16																		
15	90°	9-1/8																		
	180°	1-13/16	3	4-1/4	3	2.00	3.00	2.00	5/16-18 x 1/2 DP	.875 .874	1-7/8	.188 .190	.771 .761	1-1/2	.98	2	.44	.44	7/16-20 SAE #4	1-1/16
	360°	15-3/8																		
20	90°	11-3/16																		
	180°	14-1/16	3	5	4	2.50	3.50	2.00	3/8-16 x 1/2 DP	1.125 1.124	1-7/8	.250 .252	.986 .976	1-1/2	1.18	2-1/2	.50	.44	9/16-18 SAE #6	1-1/4
	360°	19-11/16																		
25	90°	12-9/16																		
	180°	15-1/2	3-1/2	6	4	2.50	4.50	2.00	1/2-13 x 3/4 DP	1.375 1.374	2-1/4	.313 .315	1.201 1.191	1-3/4	1.38	3	.50	.44	9/16-18 SAE #6	1-1/2
	360°	20-5/8																		
32	90°	16-5/8																		
	180°	21-1/8	5	8	5	3.00	5.00	2.50	3/4-10 x 1 DP	1.750 1.749	3-1/2	.375 .377	1.542 1.532	3	1.77	3-3/4	.58	.56	3/4-16 SAE #8	1-15/16
	360°	29-3/8																		

**Dimensions for metric units (mm)**

Model	Rotation	A	B	C	D	E	F	H	J	K	L	M P <sub>9</sub>	N	O	P	R	S	T	U*	V
10	90°	169.9																		
	180°	209.6	50.8	76.2	50.8	40	50	40	M6 x 1 x 10 DP	12.00 11.98	22.2	4	10.9 10.8	15	15	38.1	9.9	7.9	1/8	19.1
	360°	290.5																		
15	90°	231.8																		
	180°	284.2	76.2	108.0	76.2	50	80	50	M8 x 1.25 x 13 DP	22.00 21.98	47.6	6	18.5 18.4	38	25	50.8	11.1	11.2	1/4	27.0
	360°	390.5																		
20	90°	284.2																		
	180°	357.2	76.2	127.0	101.6	63	90	50	M10 x 1.5 x 13 DP	28.00 27.98	47.6	8	24.0 23.8	38	30	63.5	12.7	11.2	1/4	31.8
	360°	500.1																		
25	90°	319.1																		
	180°	393.7	88.9	152.4	101.6	63	115	50	M12 x 1.75 x 19 DP	34.00 33.98	57.2	10	29.0 28.8	44	35	76.2	12.7	11.2	1/4	38.1
	360°	523.9																		
32	90°	422.3																		
	180°	536.6	127.0	203.2	127.0	80	125	63	M20 x 2.5 x 25 DP	42.00 41.98	88.9	12	37.0 36.8	76	45	95.3	14.8	14.2	1/2	49.2
	360°	746.1																		

\* BSPP/G



### Three Position Actuator (3)

In addition to the standard two position actuators, three position units are also available. All standard options are also available.

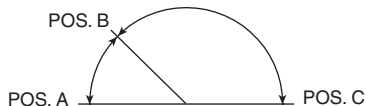

#### Operation:

A standard double rack unit is fitted with stop tubes of varying lengths on the upper rack. Pressurizing port C-2 (with ports C-1, C-3 exhausted) causes counterclockwise pinion rotation to angular position A. Alternately applying pressure to C-1 (with C-2 and C-4 exhausted) will cause clockwise rotation to angular position C. Both positions A and C are at end of stroke, thus typical end cap options such as cushions, bumpers, and stroke adjusters will operate at these positions only.

Position B is obtained by pressurizing all ports. Pressure applied to the upper floating pistons centers the rack between the stop tubes, rotating the pinion to position B. The lower rack is free floating as the forces are equal on both ends.

#### Dimensional Data:

Three position actuator dimensions are identical to the standard double rack units. If stroke adjusters are specified they will be fitted to the upper rack, flow controls and cushions will be on the lower rack. Rotational tolerances are given in the chart to the right.

#### Output Torque:

Output torque of the multiple position actuator is equivalent to the torque output of the same size single rack unit. The chart to the bottom right gives selected torque values for specified pressures.

#### Ordering Information:

Three position actuators can be ordered by inserting a 3 into the “configuration” space in the model code. The desired middle and total rotation should be stated in the model code separated by a “/”. The beginning position, 0°, need not be specified. For example: **LTR153-045/180-AB21-C** is a standard, three position actuator. Position A is 0°, position B is 45°, and position C is 180°.

**CAUTION:** Keep loop pressure drops low for proper operation.

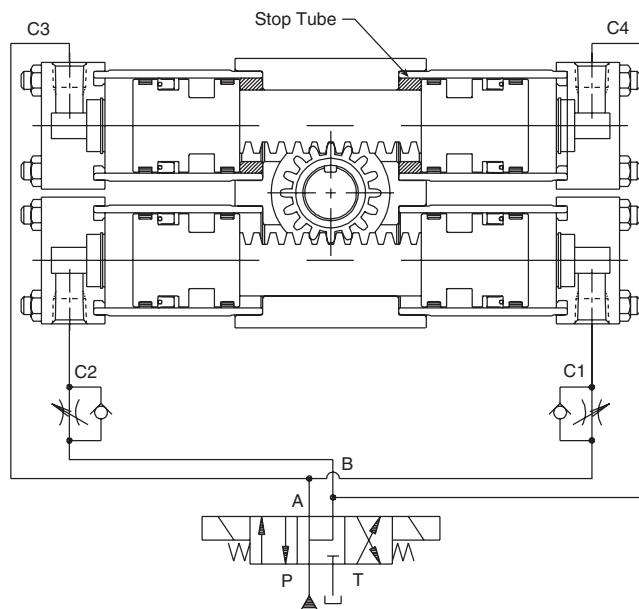

#### Rotation Tolerances

Model	Total Rotation, Degrees	Between Positions, Degrees <sup>1</sup>	Backlash Minutes
103	-0, +5	±1	50
153	-0, +4	±1/2	40
203	-0, +3	±1/2	30
253	-0, +3	±1/2	30
323	-0, +2	±1/4	15

1. Measured from centers of backlash.

#### Theoretical Output Torque, (in-lb) at Specified Pressure

Model	100 psi (6.8 Bar)	500 psi (34 Bar)	1000 psi (68 Bar)
103	39	197	395
153	118	590	1180
203	282	1410	2820
253	430	2148	4295
323	1141	5703	11407

NOTE: When magnetic piston ring option “M” is ordered, all pistons will be so equipped. The pressure rating is derated by 50% with the magnetic piston option, due to aluminum cylinder tube being used.

**A**

Rack & Pinion Actuators

HUB Series

LTR Series

HTR Series

M Series

**Antibacklash Actuator (7)**

An antibacklash actuator is used to obtain precision positioning at the end of rotation. The backlash normally associated with rack and pinion actuators is eliminated by this unique configuration.

**Operation:**

A double rack unit is modified for actuation on one end only. Alternately pressurizing C-1 or C-2 causes clockwise and counter-clockwise rotation, respectively. Backlash in the rack & pinion is eliminated as the pinion is tightly “trapped” between both racks at the end of stroke, preventing any further motion.

**Dimensional Data:**

Antibacklash actuators are similar in size and configuration to standard double rack units with one set of shorter cylinders. The table to the right shows dimensions for this shorter side. If cushions, stroke adjusters or port flow controls are ordered, they will be fitted to the powered rack side.

**Output Torque:**

Output torque of the antibacklash actuator is equivalent to the torque output of the same size single rack unit. The chart to the bottom right gives selected torque values for specified pressures.

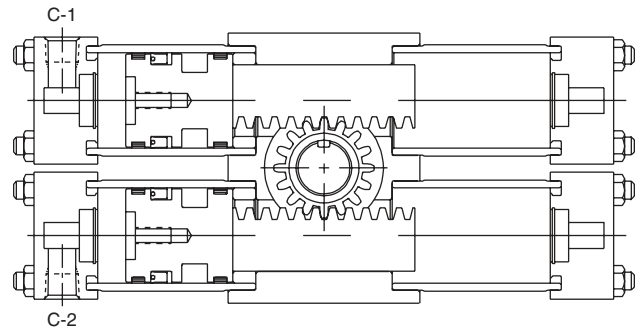
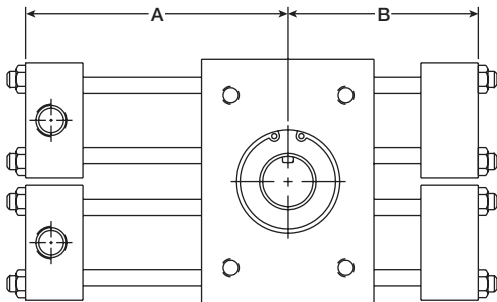

Model	Rotation	A		B	
		inch	mm	inch	mm
107	90	3-3/4	95	2-3/4	70
	180	4-1/8	105	3-3/4	95
	360	5-3/4	146	5	127
157	90	4-9/16	116	3-5/16	84
	180	5-5/8	143	4-9/16	116
	360	7-11/16	195	6-5/8	168
207	90	5-5/8	143	4-1/8	105
	180	7-1/16	179	5-5/8	143
	360	9-7/8	251	8-1/2	216
257	90	6-5/16	160	4-3/8	111
	180	7-3/4	197	6-5/16	160
	360	10-5/16	262	8-13/16	224
327	90	8-5/16	211	5-13/16	148
	180	10-9/16	268	8-5/16	211
	360	14-11/16	373	12-7/16	316

**Theoretical output torque, (in-lb) at specified pressure**

Model	100 psi (6.8 bar)	500 psi (34 bar)	1000 psi (68 bar)
107	39	197	395
157	118	590	1180
207	282	1410	2820
257	430	2148	4295
327	1141	5703	11407

**Ordering Information:**

Antibacklash actuators can be ordered by inserting a “7” into the “configuration” space in the model code. For example: **LTR157-180F-AR21-C** is a hydraulic antibacklash actuator with a theoretical output torque of 1000 in-lb at 1000 psi.

The optional stroke adjusters make the rotation variable between 120° and 180°. The preload key option on the shaft is also specified to eliminate any backlash in the key and flange coupling interface.

**A**  
 Rack & Pinion  
 Actuators

**HUB**  
 Series

**LTR**  
 Series

**HTR**  
 Series

**M**  
 Series

**Port Location (1, 2, 3, 4, 5)**

End caps can be assembled to the units with ports facing different directions as shown.

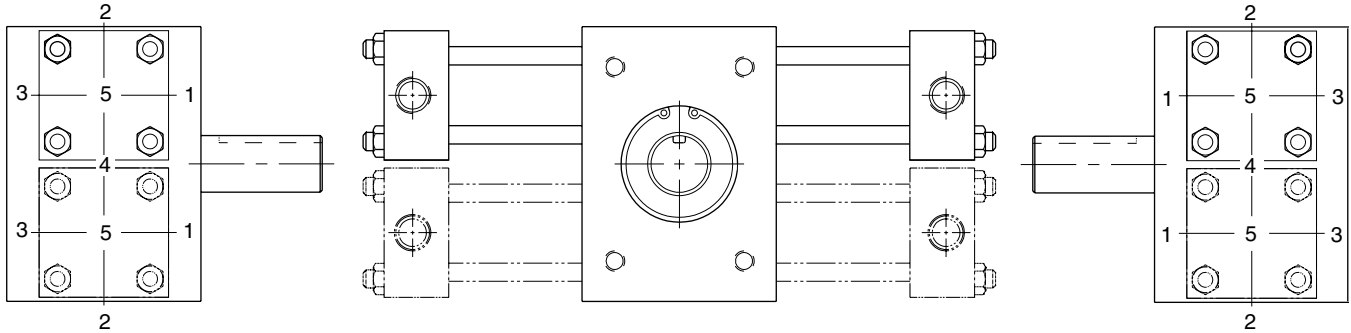

**NOTE:**

1. Port position 1 is standard.
2. Port positions 2, 3 and 4 are standard options available at no additional cost.
3. Port position 4 available with single rack actuators only.
4. For port position 5, consult factory.

**Port Threads (1, 2, 4, 5, 6)**

Model	Standard SAE Straight Thread (1)	NPT (2)	BSPP/G (4)	Metric DIN (5) & ISO (6)
10	7/16 - 20 (SAE 4)	1/8	1/8	M10 x 1
15	7/16 - 20 (SAE 4)	1/4	1/4	M14 x 1.5
20	9/16 - 18 (SAE 6)	1/4	1/4	M14 x 1.5
25	9/16 - 18 (SAE 6)	1/4	1/4	M14 x 1.5
32	3/4 - 16 (SAE 8)	3/8	1/2	M22 x 1.5

**ISO 6149/1 Port Identification**

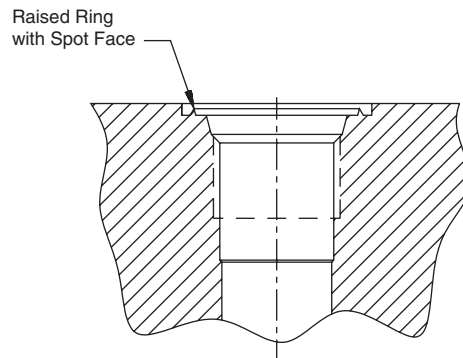

A
Rack & Pinion Actuators
HUB Series
LTR Series
HTR Series
M Series

**Cushions (1, 2, 3, 4) \***

The standard cushions operate over the last 30° of rotation in either CW, CCW or both directions. A floating bushing ensures no binding of the cushion spear. For severe operating conditions, four cushions should be fitted on double rack units. All cushions are fully adjustable. On double rack units with type 1, 2 or 3, cushion adjustment will be located on the upper cylinder.

\* For gear train durability, see table below.

**Standard Cushion Adjuster Needle Locations**

Port Position	Cushion Adjuster Position
1	2
2	3
3	2
4**	3
5	Consult Factory

\*\* On single rack only

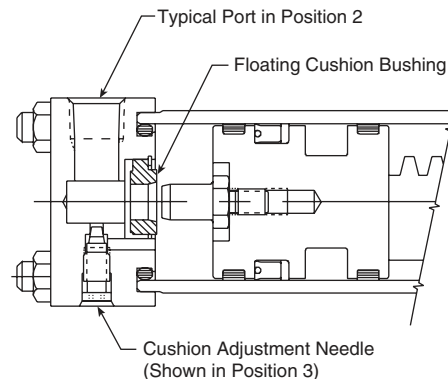

**High Performance Cushion (8)**

(This option available with double rack units only)

By combining the output/exhaust flow from two cylinders, then routing it across a single cushion needle, cushion performance is improved. The increased volume passing over the needle provides better control. This unique circuit eliminates two pipe or tubing tees.

**Operation:**

The work ports of a standard directional valve are plumbed to ports C-1 and C-2. Port A-1 is plumbed directly to A-2, and port B-1 is plumbed to B-2. When pressure is applied to port C-1 (clockwise shaft rotation), fluid is also directed through line A to the other rack. Exhaust flow from B-2 through B-1 is directed through the cushion bushing and cushion adjustment at port C-2. When the cushion spear closes off the main passage, total flow from both end caps is directed across one cushion adjustment needle, equalizing back pressure and improving control. Alternatively, pressurizing C-2 and exhausting C-1 reverses the operation.

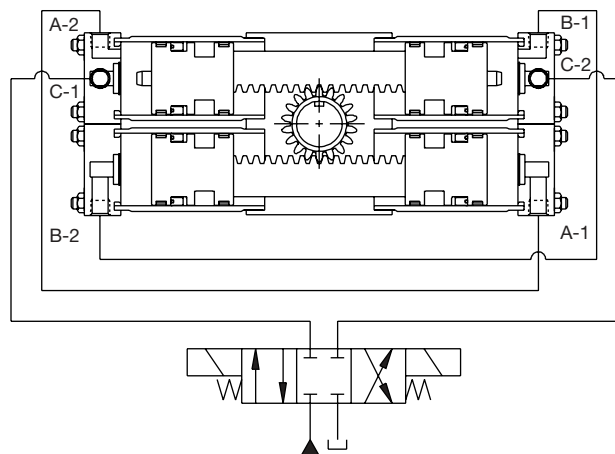

Work ports C-1, C-2 port position	Cushion adjustment position	Connection ports A-1, A-2 & B-1, B-2 port position
1	2	3
2	3	1
3	2	1

**Dimensional Information:**

Units are identical to standard double rack and pinion units, with the exception of porting location. This chart describes the location of the ports.

**Suggestion:** Use Type 4 or Type 8 cushion arrangements for double rack actuators. Use Type 1, 2 or 3 cushion arrangements exclusively for single rack actuators.

**Gear Set Durability**

The table to the right provides energy ratings based on gear train durability when using various cushion options for the LTR Series.

Model	Total energy capacity (in-lb)		Port to port ΔP (PSID)	
	Code 1,2,3	Code 8	Code 1,2,3	Code 8
LTR101	141	N/A	800	N/A
LTR102	141	303	400	800
LTR151	348	N/A	650	N/A
LTR152	348	732	325	650
LTR201	936	N/A	750	N/A
LTR202	936	1982	375	750
LTR251	1098	N/A	550	N/A
LTR252	1098	2223	275	550
LTR321	2029	N/A	400	N/A
LTR322	2029	3222	200	400

**A**  
 Rack & Pinion Actuators  
 HUB Series  
 LTR Series  
 HTR Series  
 M Series

**Stroke Adjusters (D, E, F) 30°**

Fine control of the end of travel points of the rotary actuator can be obtained by specifying stroke adjusters. These operate by reducing the maximum travel of the actuator by up to 30° in each rotational direction. Adjustment within this range is made by the user. Several types of stroke adjuster are available. The design illustrated is suitable for applications requiring infrequent adjustment.

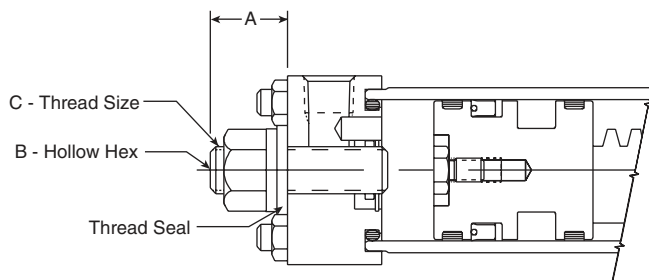

**Stroke Adjusters and Cushions**

The addition of stroke adjusters requires an increase in build length. On double rack units with cushions, the cushion is fitted to the upper rack and the stroke adjuster to the lower. (Consult factory.)

The increase in build length, for both single and double rack units, is shown as dimension A in the table. Cushion performance may be affected by the addition of a stroke adjuster. Please consult the factory in critical applications.

Model	One (1) turn adj.	30°adjustment without cushioned end cap		10°adjustment* with cushioned end cap		B	C UNF
		inch	mm	inch	mm		
10	4.0°	.63	16	.38	10	1/8	1/4-28
15	4.2°	.88	23	1.13	29	1/4	1/2-20
20	3.1°	1.13	29	1.13	29	1/4	1/2-20
25	3.3°	1.13	29	1.13	29	1/4	1/2-20
32	2.6°	1.50	38	2.13	54	3/8	3/4-16

\* Standard cushions operate over the last 30° of standard rotation. Stroke adjuster will decrease the effective cushion length by the amount of inward adjustment.

**CAUTION:** Due to end of stroke loading on some applications, four stroke adjusters may be needed with double rack actuators to avoid pinion gear damage.

**Port Flow Controls (P, R, S)**

Built in meter-out flow controls provide adjustment of actuator speed and eliminate the cost and space needed for externally plumbed components. A separate ball check is used to provide free flow in the opposite direction. Flow controls may be ordered in conjunction with cushions or stroke adjusters.

Four port flow controls are suggested with double rack actuators to avoid pinion gear damage.

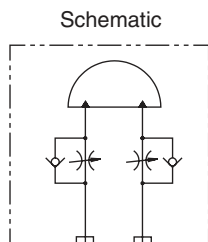
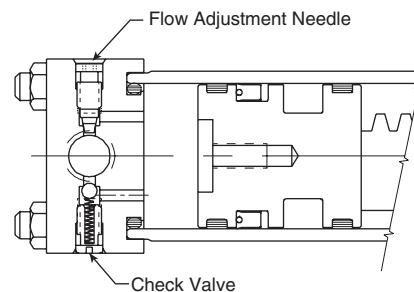

**Standard Adjustment Needle Locations**

Port Position	Needle Position
1	2
2	3
3	2
4*	3

\* On single rack only

**NOTE:** When both cushions and port flow controls are specified the end caps will be stamped "C" and "P" respectively near the adjustment needles.

<b>A</b>	Rack & Pinion Actuators
HUB Series	
LTR Series	
HTR Series	
M Series	



**Mounting Options:**

Inch Units (F, G, P, R)  
Metric Units (H, K, S, T)

**Flanged and Pilot Mountings**

LTR Series rotary actuators are available with options such as face/base, pilot or flanged mounting styles to suit the requirements of different applications.

**Note:** Actuators are shipped with mounting flange installed unless otherwise noted.

**Foot Flange (G, K)**

Model	Inch (G)						Metric (K)					
	A	B	C	D	E	F	A	B	C	D	E	F
10	3.25	2.00	2.625	1.375	.250	.281	82	51	67	35	7	6.5
15	4.50	3.00	3.875	2.125	.438	.406	114	76	98	54	11	11
20	4.50	4.00	3.875	3.375	.438	.406	114	102	98	86	11	11
25	5.50	4.00	4.500	3.000	.438	.531	140	102	114	76	11	13.5
32	8.00	5.00	6.500	3.500	.750	.781	N/A	N/A	N/A	N/A	N/A	N/A

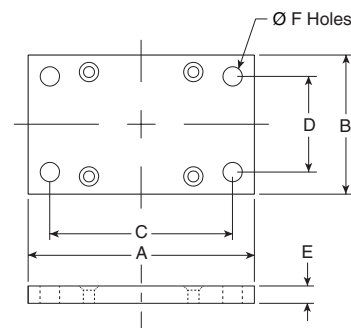

**Pilot Ring (P, S)**

Model	Inch (P)		Metric (S)	
	G	H	G	H
10	1.125	.125	28.58	3.2
15	2.001	.25	50.83	6.4
20	2.166	.23	55.04	5.8
25	2.680	.25	68.05	6.1
32	3.347	.25	85.04	6.4

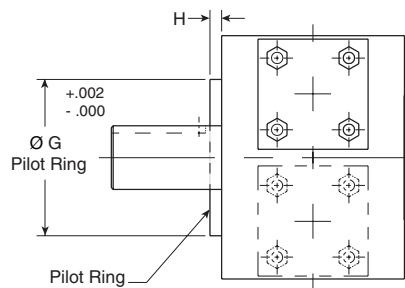

**Front (F, H) or Rear Flange (R, T)**

**NOTE:** Shaft seal cover option "S" is not available with flange mounting.

Model	Inch (F, R)							Metric (H, T)						
	J	K	L	M	N	P	Q	J	K	L	M	N	P	Q
10	4.25	2.00	3.625	1.375	.250	.281	.625	108	51	92	35	7	6.5	15
15	5.75	3.00	5.125	2.125	.438	.406	1.000	146	76	130	54	11	11	25
20	6.50	4.00	5.875	3.375	.438	.406	1.250	165	102	149	86	11	11	31
25	8.25	4.00	7.250	3.000	.438	.531	1.625	210	102	184	76	11	13.5	40
32	12.00	5.00	10.000	3.000	.750	.781	2.000	305	127	254	76	19	22	48

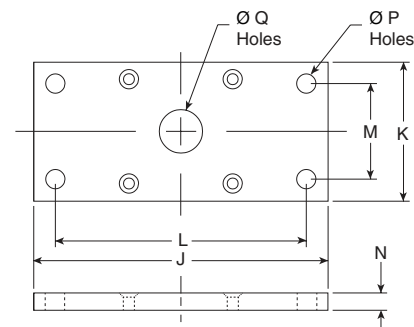



**Shaft Options (A, E, R)**

Units are equipped standard with single male keyed shaft (B, D). Double male keyed (C, F) also available as shown on page A36. Also available:

**Female Keyed (A)  
Metric Female Keyed (E)**

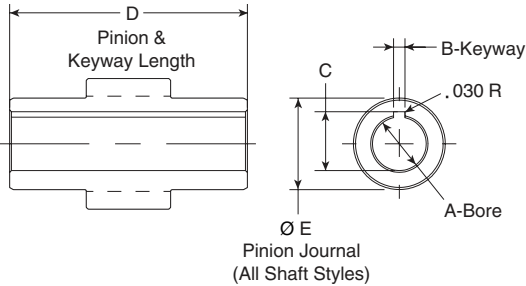

**NOTE:** Female keyed pinions are designed primarily for pneumatic service. Review shaft stresses before using in a hydraulic application.

**Dimensions, inches (A)**

Model	A	B	C	D	E
10	.375	.094	.428	1-13/16	.59
	.377	.096	.438		
15	.500	.125	.560	2-11/16	.98
	.502	.127	.570		
20	.750	.187	.837	2-23/32	1.18
	.752	.189	.847		
25	1.000	.250	1.083	3-1/8	1.38
	1.002	.252	1.093		
32	1.250	.250	1.367	4-9/16	1.77
	1.252	.252	1.377		

**Dimensions, mm (E)**

Model	A	B P9	C	D	E
10	9.05	3	10.65	46.0	15.0
	9.00		10.40		
15	12.05	4	14.05	68.1	24.9
	12.00		13.80		
20	20.05	6	23.05	68.8	30.0
	20.00		22.80		
25	25.05	8	28.55	78.7	35.0
	25.00		28.30		
32	32.05	10	35.55	115.8	45.0
	32.00		35.30		

**Preload Key (R)\***

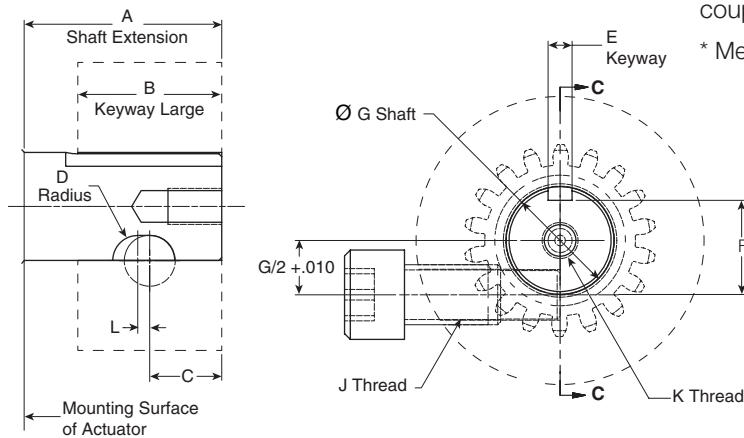

The preload key option is recommended for use with available Parker transition coupler flanges or any time coupling backlash is not desired.

\* Metric preload key option not available as a standard option.

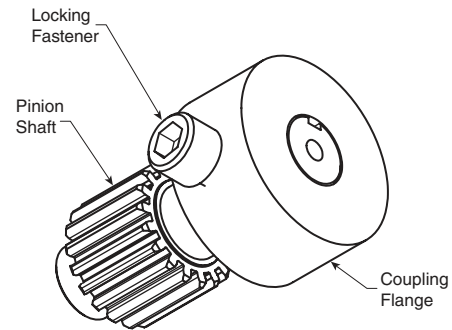

**Dimensions, inches (R)**

Model	A	B	C	D	E	F	G	H	J	K	L
10	7/8	5/8	.375	.156	.125	.430	.500	1-1/2	3/8-24	10-32 x 3/8 DP	.125
					.127	.425	.499				
15	1-7/8	1-1/2	.812	.219	.188	.771	.875	2	1/2-20	5/16-24 x 1/2 DP	.125
					.190	.761	.874				
20	1-7/8	1-1/2	.812	.250	.250	.986	1.125	3	5/8-11	3/8-24 x 9/16 DP	.125
					.252	.976	1.124				
25	2-1/4	1-3/4	1.000	.250	.313	1.201	1.375	3-1/2	3/4-10	3/8-24 x 9/16 DP	0
					.315	1.191	1.374				
32	3-1/2	3	1.500	.437	.375	1.542	1.750	4	1-8	1/2-20 x 3/4 DP	0
					.377	1.532	1.749				

**Magnetic Piston (M)**

This option prepares the actuator for use with Reed and Hall Effect switches. The “M” option should be specified to provide a magnet on the cylinder piston and aluminum cylinder tubes. *The pressure of the actuator is derated by 50% with the magnetic piston option due to the aluminum cylinder tubes.*

**Order switches separately from the Sensors section.**

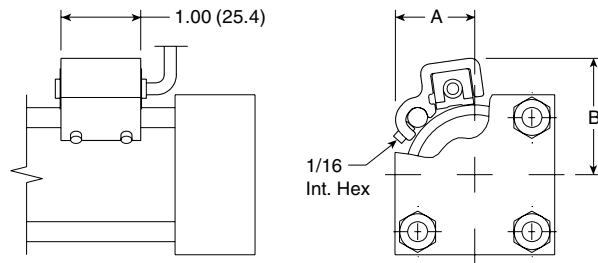

Model	A inch (mm)	B inch (mm)
10	.84 (21)	1.22 (30)
15	.99 (25)	1.46 (37)
20	1.27 (32)	1.68 (43)
25	1.45 (37)	1.89 (48)
32	1.71 (43)	2.20 (56)

**Shaft Seal Covers (S)**

Shaft Seal covers are designed to prolong bearing life by isolating them from external contamination and pressure. They are designed for use with standard male shafts only (not hollow shafts). *Shaft seals are not available with flange mounting.*

**Specifications**

**Max. Pressure Differential:** 500 psi (34 bar)

**Material:** Anodized Aluminum

**Shaft Seal:** Double Lip Wiper

**Body Seal:** O-Ring

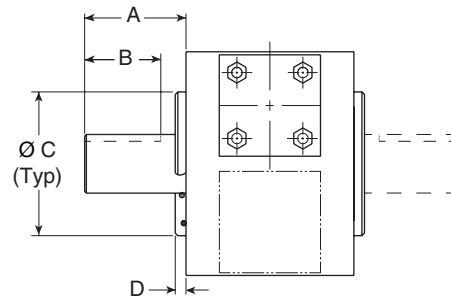

Model	A		B		C		D	
	Inch	mm	Inch	mm	Inch (+.000, -.002)	mm (+.00, -.05)	Inch	mm
10	7/8	22	1/2	12	1.875	48	.25	7
15	1-7/8	46	1-5/16	33	3.000	76	.38	10
20	1-7/8	46	1/5/16	33	3.250	83	.38	10
25	2-1/4	56	1-5/8	41	3.625	92	.38	10
32	3-1/2	88	2-7/8	73	4.480	114	.38	10

**A**

**Rack & Pinion  
Actuators**

**HUB  
Series**

**LTR  
Series**

**HTR  
Series**

**M  
Series**

### Piston Seals (V, W)

The floating Wear-Pak piston fitted as standard to all LTR Series rotary actuator employs a filled PTFE wear band to prevent metal-to-metal contact. The hydraulic LTR Series actuator uses a Molythane Polypak seal, which is self-energizing for improved sealing. The Molythane seal is wear, roll and extrusion resistant. For higher temperatures or use with synthetic fluids, Fluorocarbon seals should be specified; for water glycol or high water content fluids, carboxylated nitrile seals are available.

### Filtration

Effective filtration is vital to the long life and satisfactory performance of a rotary actuator. If the piston seals of a rack and pinion rotary actuator are worn or damaged, fluid leaks past the piston and will enter the gear housing.

Any external leakage from the gear housing indicates worn or damaged piston seals. Seals and tubes should be examined and, if necessary, be replaced at the earliest opportunity.

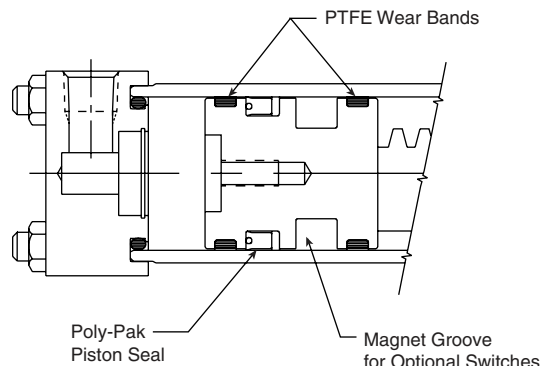

### Seal Options

Seal option code	Seal type	Wear ring type	Fluid medium	Temperature range	Hydraulic filtration
Omit (Standard)	Molythane	Filled PTFE	General purpose applications, petroleum-based fluids	-40°F to 180°F (-40°C to 82°C)	ISO Class 17/14 Cleanliness Level
Option V	Fluorocarbon	Filled PTFE	High temperature operation, special synthetic fluids	-20°F to 250°F (-29°C to 121°C)	
Option W	Carboxylated Nitrile	Filled PTFE	Water-based fluids	30°F to 180°F (0°C to 82°C)	

### Feedback Packages

Feedback packages available for use with LTR Series rotary actuators include:

- Precision feedback potentiometer (J)
- Precision resolver feedback (H)

The feedback packages may be ordered as part of the model code. See Sensors section for specifications.

### Seal Kit Ordering Information

- Standard units are equipped with nitrile seals.
- Optional seal compounds are available.
- See parts list for items contained in seal kits.

<b>PSK</b> Parker Seal Kit	—	<b>LTR322</b> Base Model	<b>V</b>
			<b>Omit</b> Nitrile Seals (Std)
			<b>V</b> Fluorocarbon Seals
			<b>Q</b> Quad Ring Piston Seals
			<b>W</b> Carboxylated Nitrile (Piston Seals Only)

**A**

Rack & Pinion Actuators

HUB Series

LTR Series

HTR Series

M Series

**Switch Characteristics**

**Proximity Switches**

- End Cap Mounted
- Solid State Electronics
- LED Indicator
- 10-30 VDC or 50-230 VAC/DC
- PNP and NPN Available
- Senses Cushion Spear on Piston
- Highest Cost
- Long Life

**Hall Effect Switches**

- Fully Adjustable Travel
- Solid State Electronics
- LED Indicator
- 50-30 VDC
- PNP and NPN Available
- Senses magnet band on piston (Aluminum cylinders required)
- Medium Cost
- Long Life

**Reed Switches**

- Fully Adjustable Travel
- Mechanical Reed
- LED Indicator
- 50-30 VDC or 85-150 VAC
- Senses magnet band on piston (Aluminum cylinders required)
- Lowest Cost
- Medium Life

**Proximity Switches**

The inductive type proximity switch provides end of rotation indication. The non-contact probe senses the presence of the ferrous cushion spear and has no springs, plungers, cams or dynamic seals that can wear out or go out of adjustment. The switch is solid state and meets NEMA 4, 12 & 13 specifications. For ease of wiring, the connector housing is rotatable through 360°. To rotate, lift the cover latch, position, and release.

The switch make/break activation point may occur at 0.125" to ±0.125" from end of stroke. Depending on the actuator size, this distance may cause activation at 2° to 15° before end of stroke.

A standard proximity switch controls 50-230 VAC/DC loads from 5 to 500 mA. The low 1.7 mA off-state leakage current can allow use for direct PLC input. The standard short circuit protection (SCP) protects the switch from a short in the load or line upon sensing such a condition (5 amp or greater current) by assuming a non-conductive mode. The fault condition must be corrected and the power removed to reset the switch preventing automatic restarts.

The low voltage DC switch is also available for use with 10-30 VDC. This switch is in a non-rotatable housing, but does incorporate the short circuit protection.

Both switches are equipped with two LEDs, "Ready" and "Target". The "Ready" LED is lit when power is applied and the cushion spear is not present. The "Target" LED will light and the "Ready" LED will go out when the switch is closed, indicating the presence of the cushion spear. Both LEDs flashing indicates a short circuit condition.

**NOTES:**

1. Available with or without cushions.
2. Not available with stroke adjusters.
3. Prsesure rating: 3000 psi
4. Operating temperature: -4°F to 158°F
5. Specify switch type, orientation and voltage when ordering
6. Not available on size 10 units.
7. The low voltage DC switch is available in non-rotatable style only. Consult representative for further information.

**Hall Effect and Reed Switches**

Reed and Hall Effect switches are available for use with LTR Series rotary actuators. The "M" option should be specified to provide a magnet on the cylinder piston and to use aluminum cylinders.

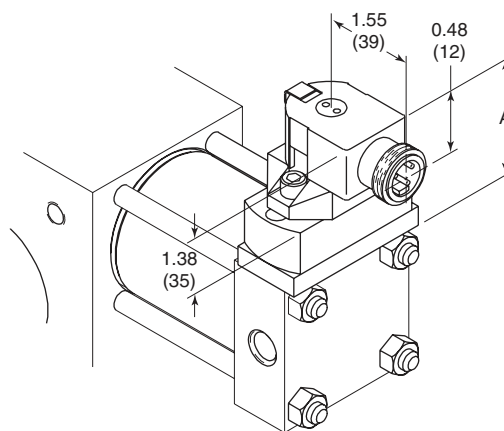

Model	A, inch (mm)	
	EPS 5	EPS 6&7
15	1.88 (48)	2.17 (55.1)
20	2.44 (62)	2.75 (69.9)
25	2.16 (55)	2.48 (63.0)
32	1.94 (49)	2.25 (57.2)

**Order proximity, Hall Effect and reed switches separately. See Sensors section for specifications and ordering information.**