

ZEUS HYDRATECH LTD

Global Suppliers of Premium Hydraulic Components

Official UK Distributor for DOMIN

T: +44(0)1172 130042. E: sales@zeushydratech.com. W: zeushydratech.com

S6 Pro Datasheet

Product Overview

The Domin S6 Pro direct drive servo valve (DDV) has been designed to achieve the best characteristics from two competing valve technologies: fluid amplified EHSV and DDVs.

The S6 Pro has the size, mass, and dynamic capabilities of the most compact EHSV, and the low quiescent leakage and reliability of the best DDV.

Key Features

- Onboard electronics with spool position feedback
- Rated flow of up to 60 l/min (at 70 Bar ΔP)
- Based on the NG06 port pattern
- Bandwidth > 190 Hz (-3 dB, up to $\pm 25\%$ FS)
- Low power consumption of less than 5 W
- Chip shear capability of greater than 400 N
- Low weight of less than 600 g

Customisation

The S6 Pro is designed to be customised. Standard modifications include:

- Choice of rated flow up to 60 l/min
- Multiple voltage or current control options
- Various seal materials available
- Non-standard configurations are available.

Contents

Technical Data	1
Performance Graphs	2
Electronics Data	3
Electronic Interface Diagrams	5
Standards Reference	6
Unit Dimensions	7
Mounting Dimensions	8

Contact Us

If you have any questions about using the S6 Pro, or if you need a non-standard configuration, we would be happy to hear from you.

Contact us using the details below and one of our team will be there to assist you.



sales@domin.co



<https://domin.co/>



33 Colston Avenue, Bristol, BS1 4UA



+1 786 396 0835 (US)
+44 (0)333 090 5140 (UK)





Technical Data

General Data		
Design	Direct Drive Servo Valve	
Actuation	Rotary-Linear	
Size	NG06	
Mounting Interface	ISO 4401-03-02-0-05	
Ambient Temperature	°C (°F)	-20 to +60 (-4 to +140)
Mass	kg (lb)	0.55 (1.21)
Vibration Resistance, All Axes ⁽¹⁾	g	30
Shock Resistance, All Axes ⁽²⁾	g	50
Hydraulic Data		
Max. Operating Pressure (P, A, B)	bar (psi)	350 (5000)
Max. Operating Pressure (T)	bar (psi)	250 (3600)
Fluid	Hydraulic Oil DIN 51524-535	
Fluid Temperature	°C (°F)	-20 to +80 (-5 to +175)
Viscosity	cSt	5 to 500
Rated Flow ⁽³⁾	l/min (US gal/min)	6 to 60 (1.6 to 15.9)
Flow Maximum	l/min (US gal/min)	130 (34.3)
Leakage at 100 bar ⁽³⁾	l/min (US gal/min)	< 1.1 (< 0.3)
Filtration	ISO 4406 (1999) 18/16/13	
Static/Dynamic Data		
Response Time at 100% Step Input ⁽⁴⁾	ms	< 3.5
Frequency Response (-3dB gain, ±25% signal) ⁽⁴⁾	Hz	> 190
Frequency Response (-90deg phase, ±25% signal)	Hz	> 120
Hysteresis	%	< 0.2
Threshold	%	< 0.05
Null Shift	%	< 1

1) BS EN 60068-2 (20-35Hz, 16g for 15 minutes per axis, 35-2000Hz, 35g for 15 minutes per axis)

2) BS EN 60068-2 (20 shocks 50g in Z axis)

3) Axis cut valve, tested at 70 bar according to ISO-10770-1

4) Measured as 90% output rise time with Δ70 bar P-T (two control edges)





Performance Graphs

Step Response (1)

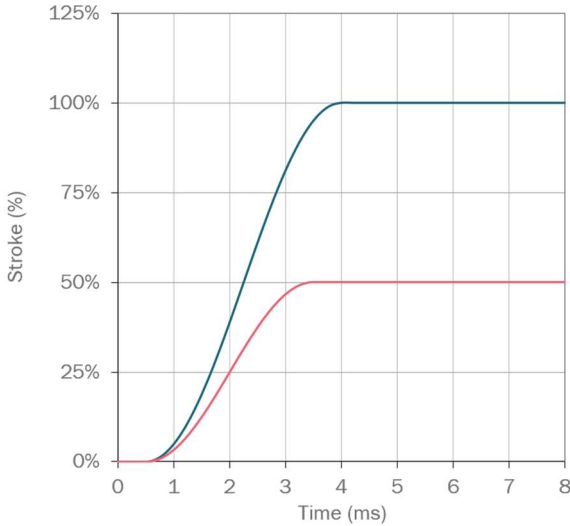

Flow vs Command

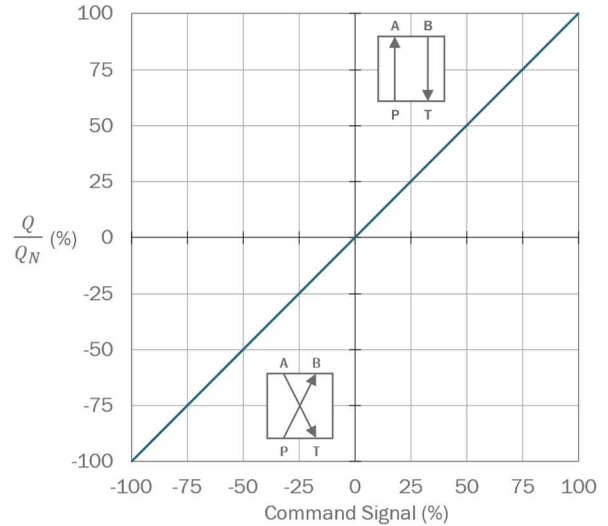

Frequency Response (1)

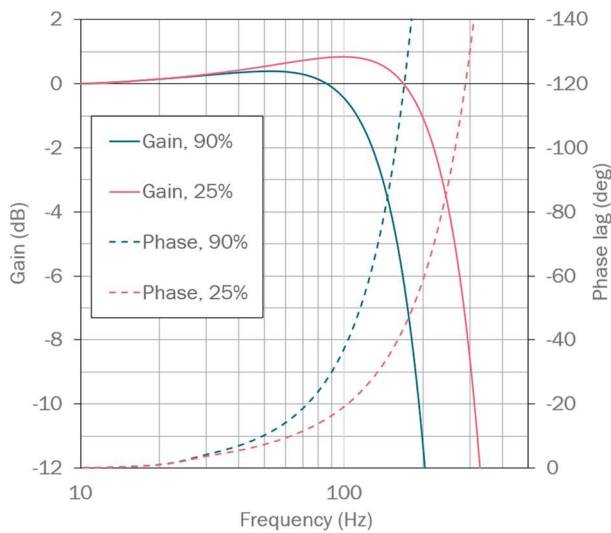

Pressure Gain

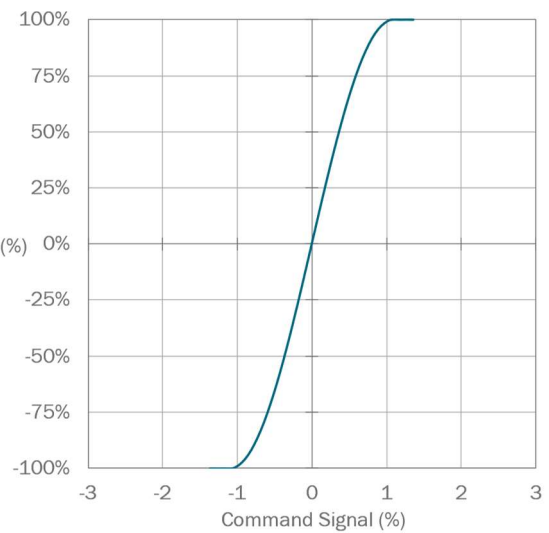

1) Measured at a 70 bar pressure drop.





Electronics Data

Ratings of the valve electronics vary based on selected command input. See the product configuration guide on page 9 of this document for details on product codes.

± 10 V

Absolute Maximum Ratings ⁽¹⁾		Min.	Typical	Max.
Supply Voltage	V	0	-	30
Differential Input Signal	V	-10.5	-	10.5
Input Signal Common Mode Offset	V	-24	-	24
Output Signal Current	mA	-50	-	50

Normal Operating Conditions				
Supply Voltage	V	22	24	30
Absolute maximum current draw ⁽²⁾	A	-	-	4.5
Differential Input Signal	V	-10	-	10
Input Impedance	k Ω	200	-	-
Output Signal	V	-10	-	10
Output Impedance	Ω	-	150	-
Output Load Impedance	k Ω	1	-	-

± 20 mA

Absolute Maximum Ratings ⁽¹⁾		Min.	Typical	Max.
Supply Voltage	V	0	-	30
Differential Input Signal	mA	-25	-	25
Input Signal Common Mode Offset	V	-24	-	24
Output Signal Current	mA	-50	-	50

Normal Operating Conditions				
Supply Voltage	V	22	24	30
Peak Current Consumption ⁽²⁾	A	-	-	4.5
Differential Input Signal	mA	20	-	20
Input Impedance ⁽³⁾	Ω	-	392	-
Output Load Impedance ⁽⁴⁾	Ω	-	-	650



S6 Pro Datasheet



+4 to +20 mA

Absolute Maximum Ratings ⁽¹⁾		Min.	Typical	Max.
Supply Voltage	V	0	-	30
Voltage Mode Differential Input Signal	mA	-25	-	25
Input Signal Common Mode Offset	V	-24	-	24
Output Signal Current	mA	-50	-	50
Normal Operating Conditions				
Supply Voltage	V	22	24	30
Peak Current Consumption ⁽²⁾	A	-	-	4.5
Differential Input Signal	mA	4	-	20
Differential Input Signal For Drive Off ⁽⁵⁾	mA	-20	-	2
Input Impedance ⁽³⁾	Ω	-	392	-
Output Load Impedance ⁽⁴⁾	Ω	-	-	650

- 1) Conditions outside the absolute maximum ratings may cause permanent damage to the valve. These are absolute ratings only. Operation of the product outside of the nominal operating conditions is not guaranteed and may affect product reliability.
- 2) The valve supply must be protected with a 5 AT fuse or equivalent overcurrent protection device.
- 3) Valves with a current command signal use a 0.1% tolerance shunt resistor to measure demand current.
- 4) The value of the shunt resistor to measure output current should not exceed stated maximum value.
- 5) A current in this range will disable the motor drive until a current outside this range is received at the command input.

Valves with Enable Function

Valves can be provided with an enable function. This allows the valve to be enabled or disabled by varying the voltage into the enable pin (see page 6 for a pin out diagram). Note that valves with a code C command type can also be enabled or disabled using the command signal; see the corresponding table above for further details.

Normal Operating Conditions		Min.	Typical	Max.
Voltage for Drive Enable	V	9	-	28
Voltage for Drive Disable	V	0	-	5
Input Impedance	Ω	50	-	-



Electronic Interface Diagrams

6 + PE Circular Connector (Code E)

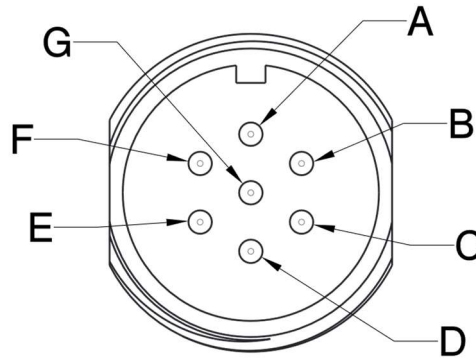

Type: Case-Mounted
Termination: Connector according to EN 175201-804/MIL 5015 equivalent, shell size 14
Number of Contacts: 7

Pin	Function	Description
A	Supply +	+24 V
B	Supply 0 V	0 V
C	Output - Enable input ⁽¹⁾	Output 0 V Reference Drive enable input ⁽¹⁾
D	Input +	Differential input signal, +
E	Input -	Differential input signal, -
F	Output +	Output signal
G	Earth	-

1) When the enable function is selected, the function of pin C is the enable input. This replaces the standard pin function.

S6 Pro Datasheet



4 Pin Circular Connector (Code E4)

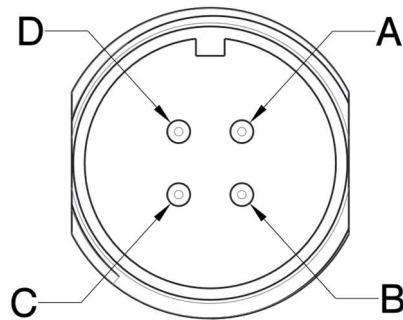

Type: Case-Mounted
Termination: Connector according to EN 175201-804/MIL 5015 equivalent, shell size 14
Number of Contacts: 4

Pin	Function	Description
A	Supply +	+24 V
B	Input +	Differential input signal, +
C	Input -	Differential input signal, -
D	Supply 0 V	0 V



Unit Dimensions

Connector Code B4

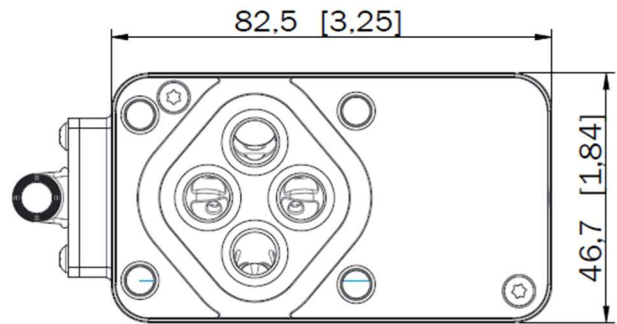
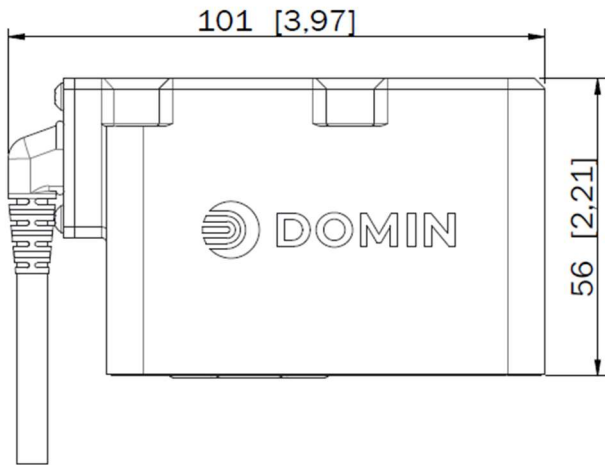

Connector Code E and E4

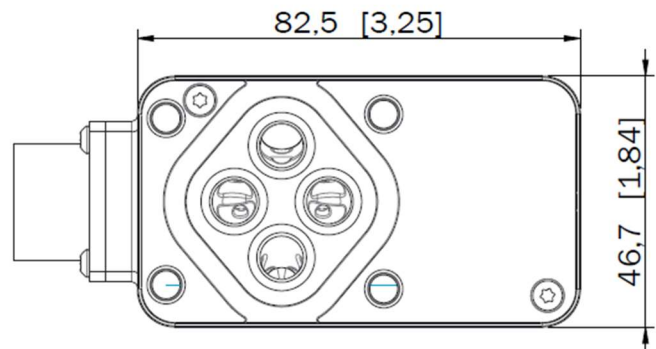
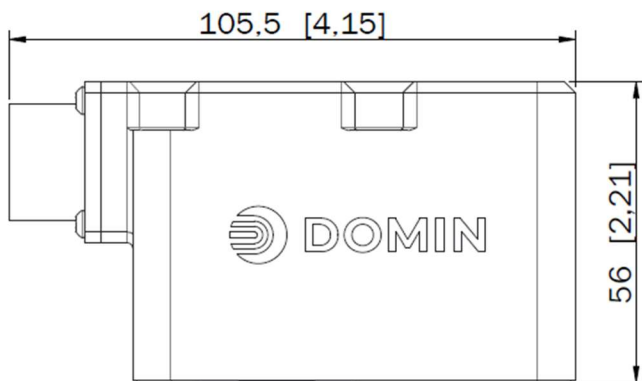

Nominal dimensions are displayed in mm. Not to scale. Note X and Y direction.



Mounting Dimensions

	P	A	B	T	F1	F2	F3	F4
Diameter Ø	mm 7.5	7.5	7.5	7.5	M5	M5	M5	M5
X Position	mm 21.5	12.7	30.2	21.5	0	40.5	40.5	0
Y Position	mm 25.9	15.5	15.5	5.1	0	-0.75	31.75	31

Bolts (F1, F2, F3, F4)

Type: M5 x 55 DIN EN ISO 4762-10.9
 Required Torque: 7.5 Nm (5.53 ft-lbf)

O-Rings (P, A, B, T)

Type: 9.25 x Ø 1.78 (ISO 3601-1-012)
 Material: NBR, EPDM or Viton, 70 Shore A
 Hardness: 70 Shore A

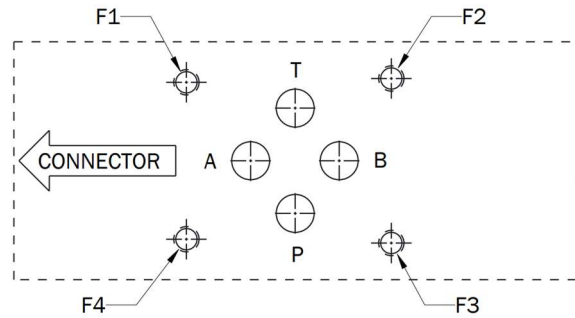

Standards Reference

- EMC Regulations: EN 61000-6-2
EN55011:1998+A1
- Performance Tests: ISO 10770-1
- Pressure Rating: ISO 10771
- Hydraulic Interface: ISO 4401-03-02-0-05

Variants on request

At Domin, we are proud of our ability to offer tailored solutions that meet our customers' specific needs. If you require a non-standard configuration, or a bespoke modification, we are confident we can provide you with the best solution. Talk to us using the contact details provided and one of our team will respond as soon as possible.



S6 Pro Datasheet



Code 1 Rated Flow	
Any value in range 19 to 60 ¹	
Rated flow in l/min for 35 bar ΔP per control edge	
R – Suffix for reversal of A and B port e.g. 60R	

Code 2 Spool Lap Condition	
A	Axis cut (1% overlap linearised)
O	3% Overlap (linearised to 50% gain over centre)
D	10% Overlap (with flow dead band)
X	For other options please enquire

Code 3 Control Method	
A	± 10 V
B	± 20 mA
C	4 to 20 mA
D	± 5 V
X	For other options please enquire
For differing input and output signals, use two letters, e.g. AC denotes ± 10V Input and 4 to 20mA output	

Code 4 Power off Position	
C	Centre
X	For other options please enquire

Code 9 Custom ID	
Assigned individually to any with customised options upon enquiry	

Code 8 Seal Material	
N	Nitrile
V	Viton
X	For other options please enquire

Code 7 Fluid Type	
R	Recommended - any hydraulic oil in accordance with DIN 51524, filtered in accordance with ISO4406 18/16/13. Compatibility with water-free synthetic fluids available on enquiry.
X	For other options please enquire

Code 6 Enable Mode	
Y	Enable mode on ²
N	No Enable Functionality

Code 5 Electrical Connector	
E	6 pin + PE circular connector ³
E4	4 pin circular connector ³
B4	4 contact, unterminated flying lead
G	G4-20P Rack and Panel connector
X	For other options please enquire

1. Flow rating set in valve software – dynamic performance measured set at 60lpm flow.
 2. Only available with connector option E
 3. EN 175201-804/MIL 5015 equivalent connector, shell size 14

